



AIRCRAFT ENGINEER



THAMES & KOSMOS

Story and Instructions

Dear Parents,

Engineering is an extremely exciting and vast field. This kit, along with its illustrated storybook and instruction manual, provides an engaging way to teach simple engineering concepts to preschool-age kids.

Read the story with your child and build the simple models of the vehicles the main characters encounter on their fun-filled family vacation. Along this roundabout journey, the characters build various vehicles to solve problems and complete tasks. As you follow the story, your child can build models of the ten vehicles in the story with your help. Large, colorful plastic building pieces make it easy for small hands to put the models together.

The models are assembled step by step using a construction system. It will require a little practice and patience at first. Please assist your children when they need your help, but also let them try to build the models by themselves. Your children will be happy to have your help with the models or assembly steps that pose particular difficulties.

We wish you and your child lots of fun building, discovering, and learning!

Safety Information

- » » » **WARNING.** Not suitable for children under 3 years. Choking hazard — small parts may be swallowed or inhaled.
- » » » Keep the packaging and instructions as they contain important information.
- » » » Store the experiment material and assembled models out of the reach of small children.

AIRCRAFT ENGINEER



**Story by
Ted McGuire**

**Illustrations by
Dan Freitas and Ashley Greenleaf**

>>> KIT CONTENTS

What's inside your kit:

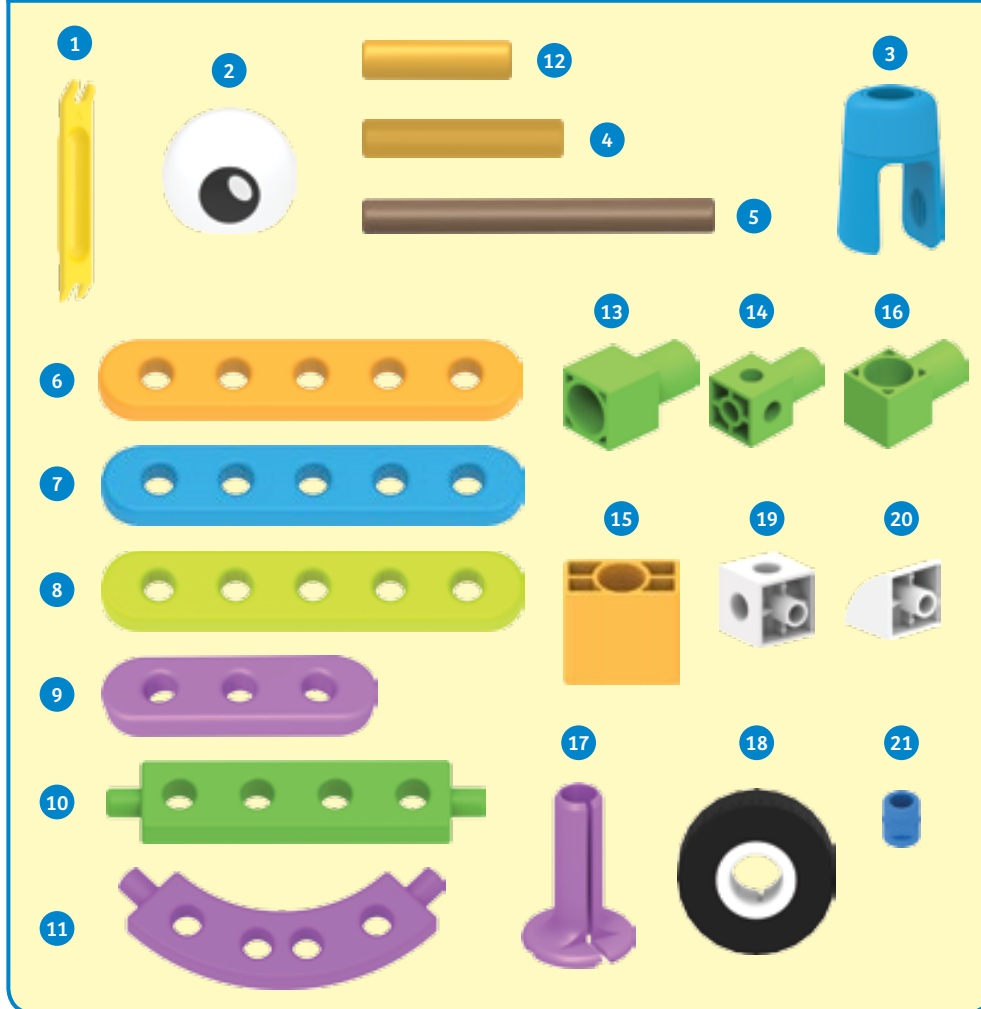

Checklist: Find – Inspect – Check off

✓	No.	Description	Qty.	Item No.
<input type="radio"/>	1	Anchor pin removal tool	1	7061-W10-B1Y
<input type="radio"/>	2	Eye	2	7261-W85-A
<input type="radio"/>	3	Connector clip	1	7261-W85-B1B
<input type="radio"/>	4	Medium dowel	7	7330-W11-A1T
<input type="radio"/>	5	Long dowel	3	7330-W11-B1D
<input type="radio"/>	6	5-hole rod, orange	1	7330-W11-D1O1
<input type="radio"/>	7	5-hole rod, blue	2	7330-W11-D1B1
<input type="radio"/>	8	5-hole rod, green	2	7330-W11-D1G1
<input type="radio"/>	9	3-hole rod, purple	2	7330-W11-E1P1
<input type="radio"/>	10	4-hole rod, green	2	7330-W11-H1G1
<input type="radio"/>	11	4-hole curved rod	2	7330-W11-J1P1
<input type="radio"/>	12	Short dowel	4	7330-W11-X1T
<input type="radio"/>	13	Dowel block with top hole	6	7331-W10-D1G1
<input type="radio"/>	14	Cube block with peg	4	7331-W10-D3G1
<input type="radio"/>	15	Dowel connector	2	7331-W10-E1O1
<input type="radio"/>	16	Dowel block with side hole	12	7331-W10-M1G1
<input type="radio"/>	17	Nail	2	8036-W10-T1P
<input type="radio"/>	18	Wheel, black	4	8036-W85-C1D
<input type="radio"/>	19	Cube block, white	7	880-W10-A1W
<input type="radio"/>	20	Convex block, white	5	880-W10-R1W
<input type="radio"/>	21	Anchor pin, short	2	880-W10-M1B

GOOD TO KNOW!

If you are missing any parts, please contact Thames & Kosmos customer service.



Meet the Omega Family!

Ty and Karlie Omega are siblings. They live in a small city called Makersville. Ty and Karlie's dad is a writer. He writes science fiction stories. Their mom is a mechanical engineer. She designs big machines used in factories.

They live in an awesome warehouse filled with tools, equipment, and building materials. There are always a number of projects going on in the warehouse.

Ty loves figuring out how things work. Karlie loves building things.

When Ty and Karlie were little, Ms. O designed Huxley, a robot that can build just about anything. For one of his first projects Huxley converted Karlie's teddy bear, Remus, into a walking, talking science bear. Now Huxley and Remus are like members of the Omega family.

Ty and Karlie's Aircraft Engineering Adventure begins ...



The Omega family was ready for a vacation. They had packed up, driven to the airport, parked the car, and checked into the flight. Ty and Karlie were sitting in the waiting area at the gate when Ms. O returned from looking at the departures screen.

"It says our flight has been cancelled because the plane hasn't

arrived yet," sighed Ms. O.

"We can build our own passenger plane, Mom!" Ty exclaimed. "Huxley can help us do it."

And with that, Karlie, Ty, and Huxley got to work assembling an airplane.

PALOMA THE PASSENGER JET

1

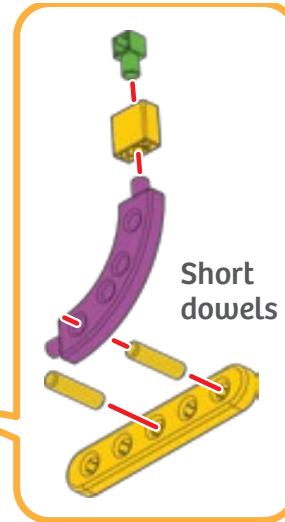
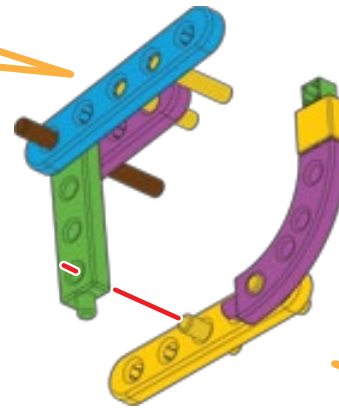
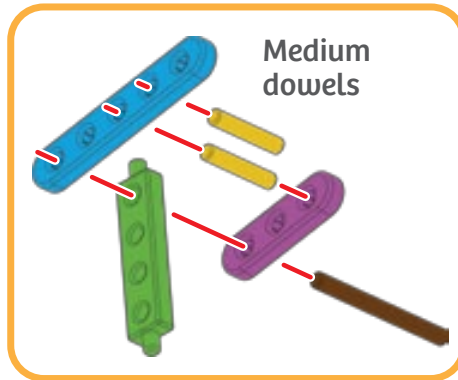

2

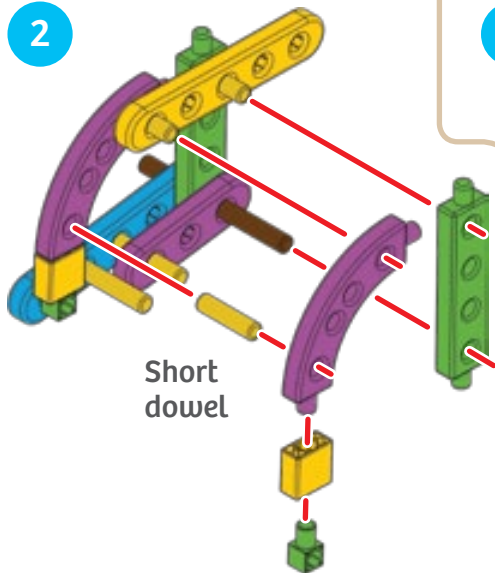

3

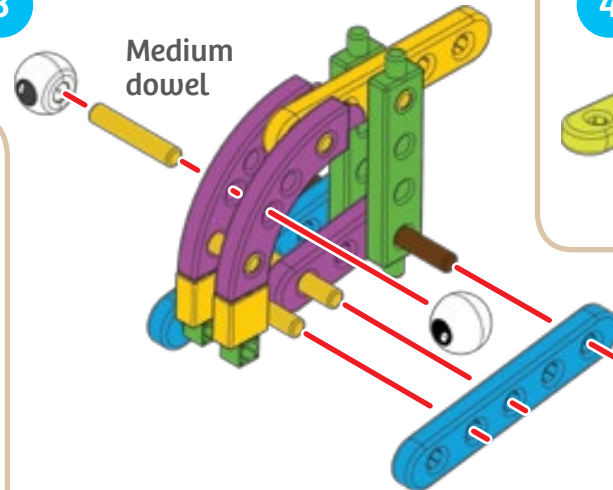

4

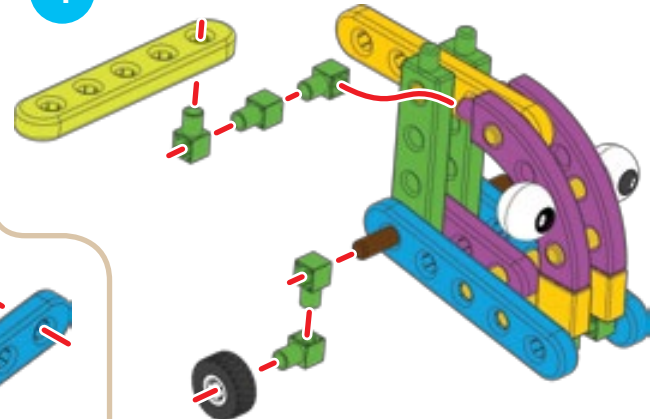

Continued >>>

5

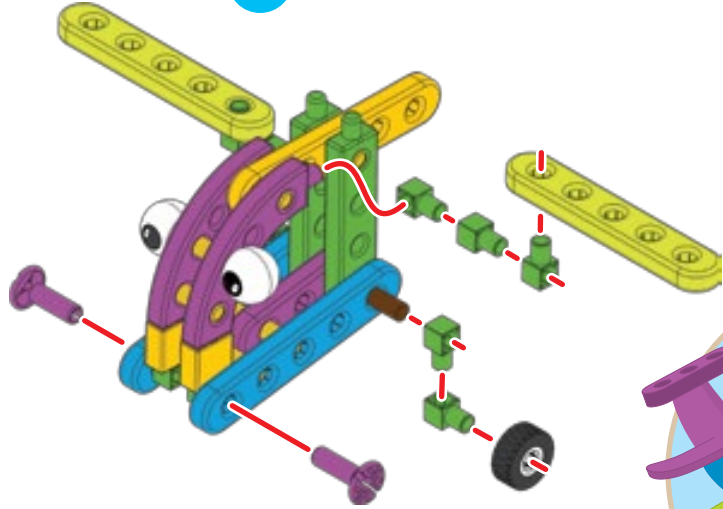

6

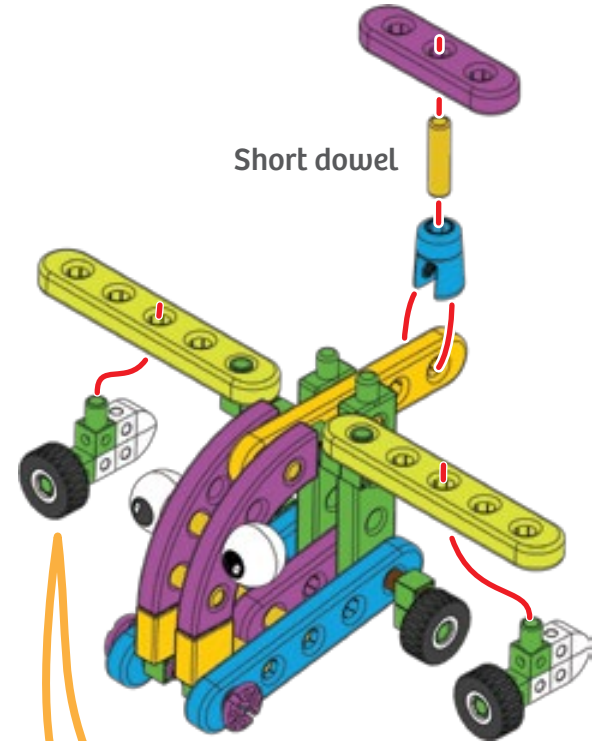

Short dowel

7

Done!

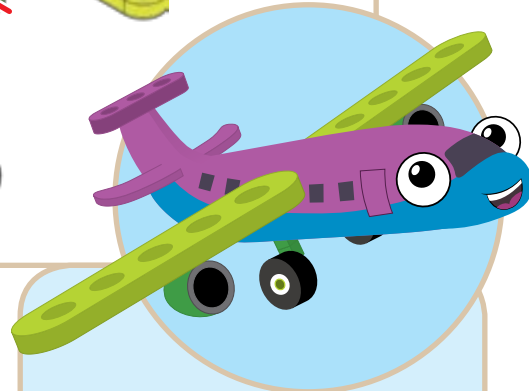
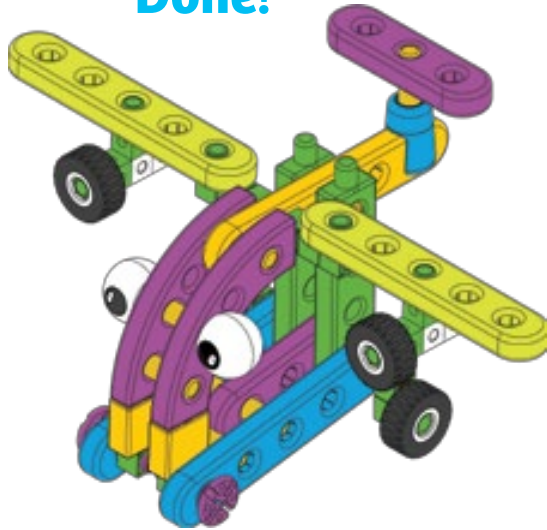

“Now boarding!” Paloma the Passenger Jet called out. “Nonstop to the tropical islands, boarding now.”

The jet carried them to the island. It was a smooth flight. Ty loved looking out the window and seeing the blue-green waters below. He even saw a pod of dolphins right before they landed.

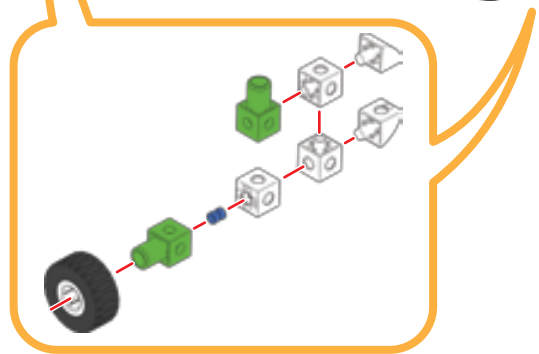

The Omegas were staying in a little group of guest cottages called the Beach Hotel. It had grass roofs and seashell walls. Outside their cottage they met a scientist named Dr. Bluewater.

"We are studying sea turtles out on a remote island, but the ocean is too wavy today for us to safely take a boat to the island," Dr. Bluewater told them.

"You're in luck because we happen to be great young engineers!" Karlie exclaimed. "We can build you a helicopter to take you to the island."



HELEN THE HELICOPTER

1



2

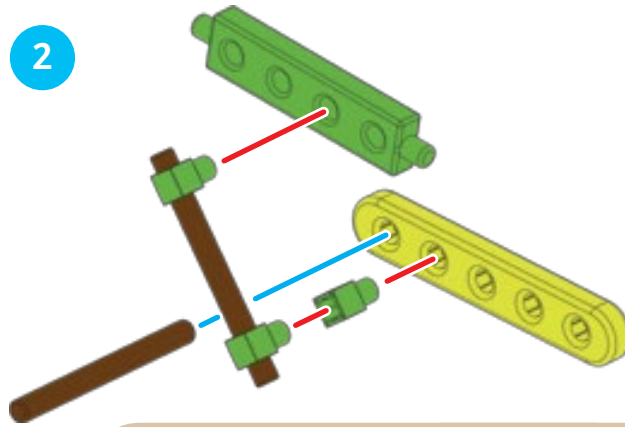

3

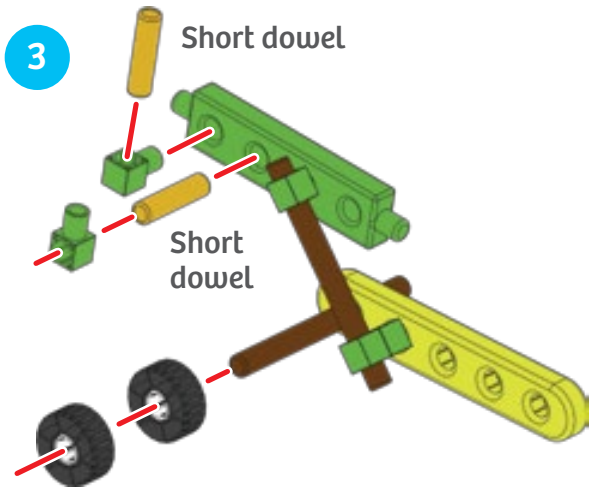

4

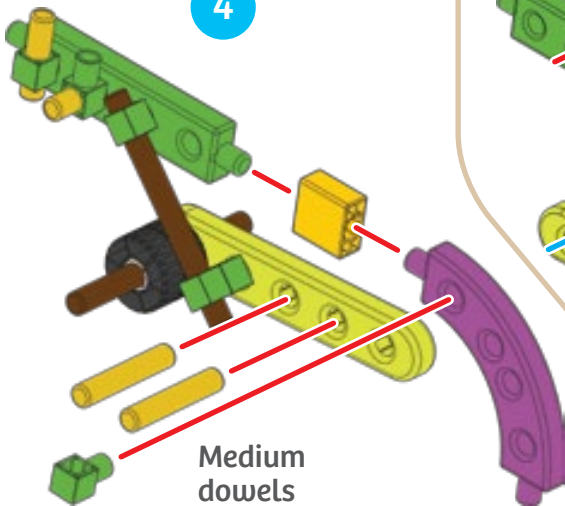

Medium dowels

5

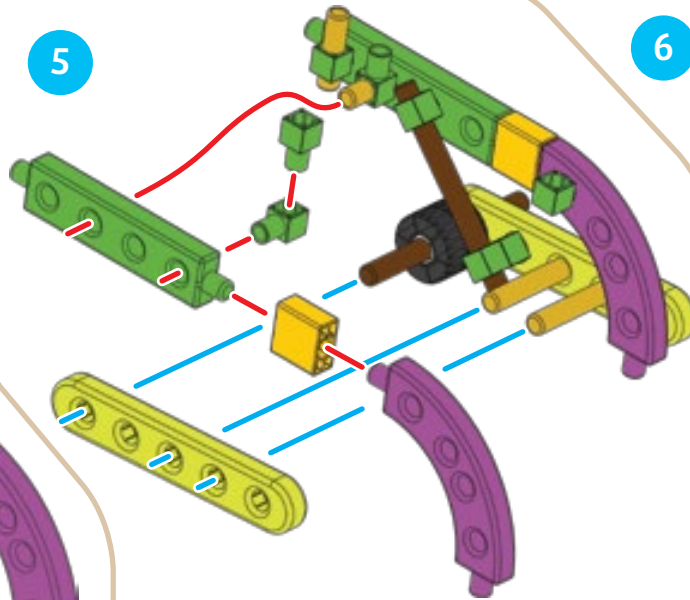

6

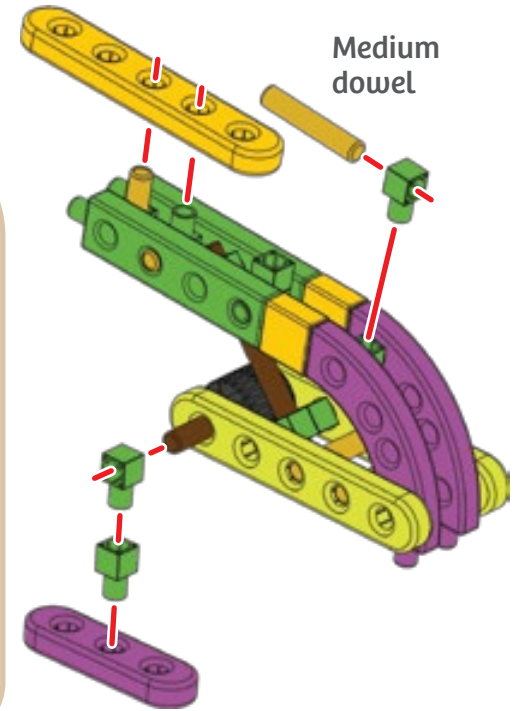

Medium dowel

7

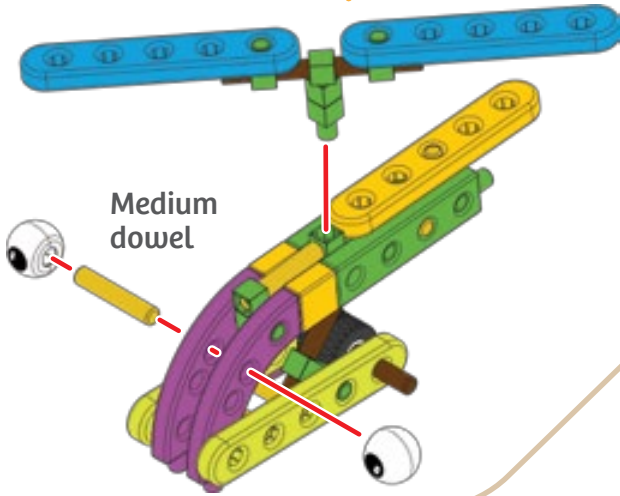
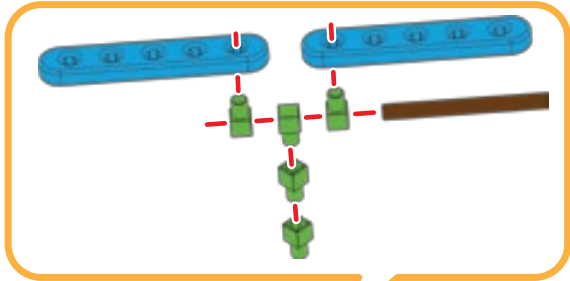

Medium
dowel

8

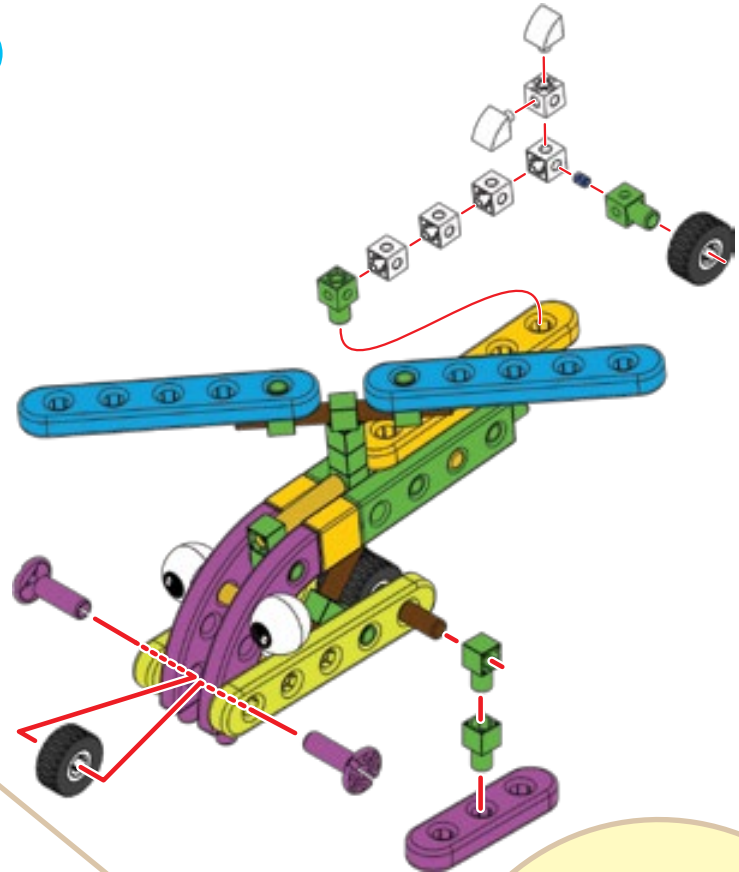

9

Done!

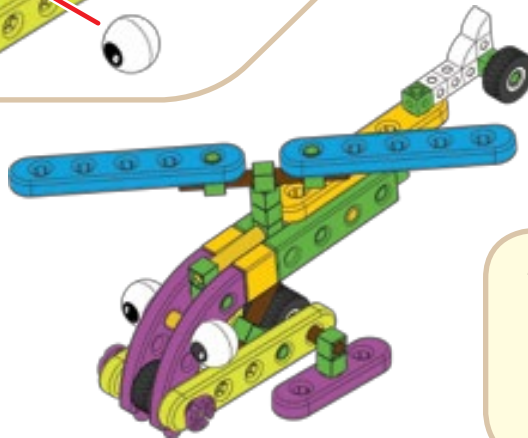

"Hello! I'm Helen the Helicopter.
I can fly you out to the sea
turtle island. My rotor can lift
us into the air."

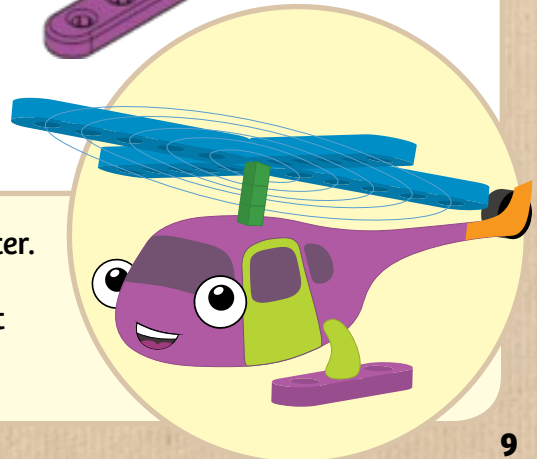

Helen flew Ty, Karlie, Huxley, Remus, and Dr. Bluewater out to the island.

After dropping Dr. Bluewater off, he gave them an "I 'heart' sea turtles" sticker and thanked them. "Thanks so much kids! The sea turtles thank you too!" said Dr. Bluewater.

"Okay, time to head back," Karlie said.

"Oh no!" Huxley exclaimed. "The tide has come in and now there is nowhere for our helicopter to take-off!"

"I know what we can do!" responded Ty. "We can build a seaplane which has pontoons that allow it to take-off and land in the water!"

"Cool!" said Karlie. The kids and Huxley started building.



CECILE THE SEAPLANE

1

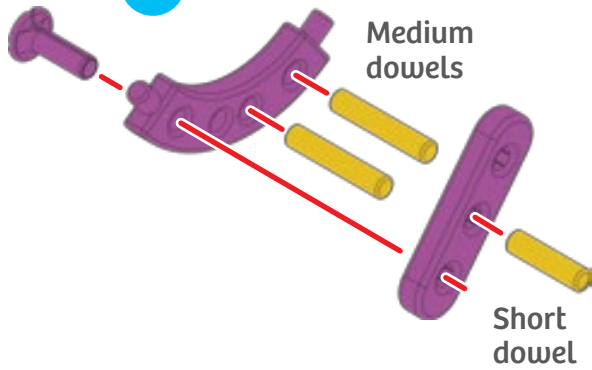

2

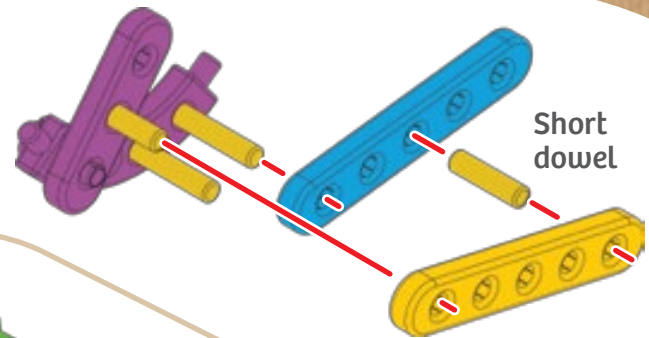

4

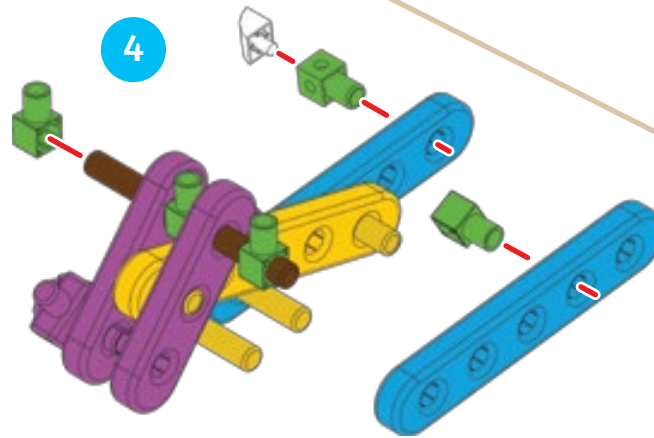

3

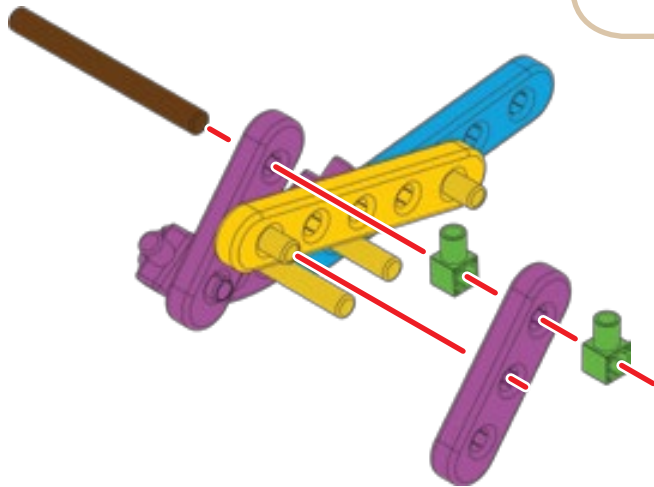

5

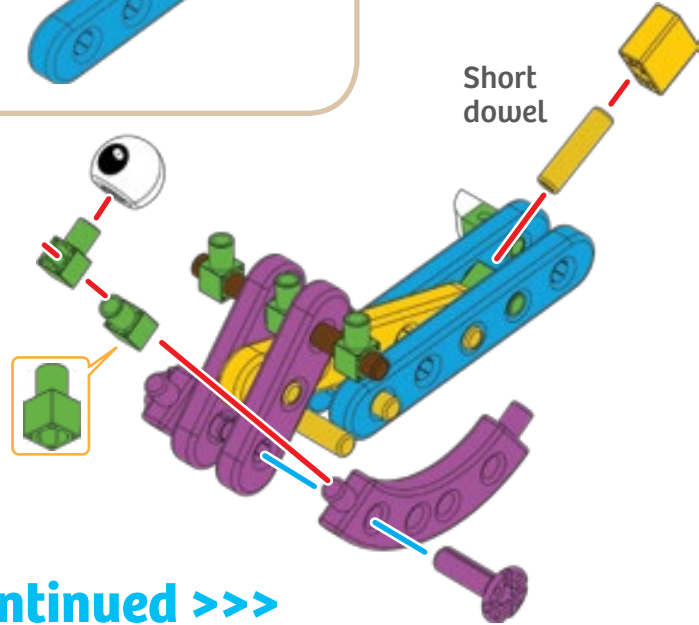

Continued >>>

6

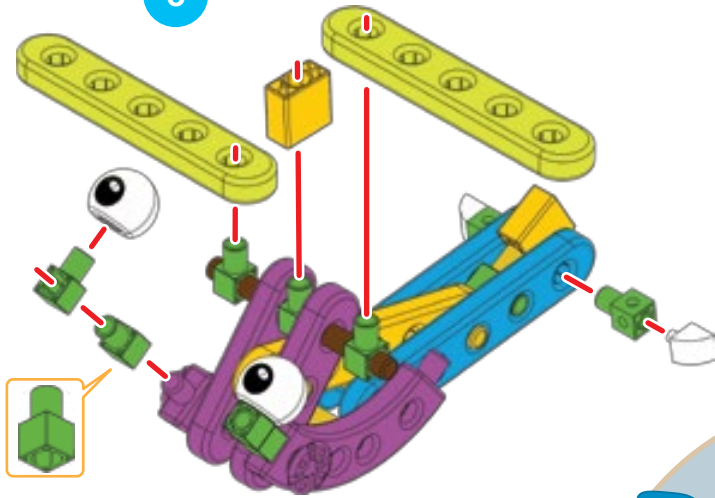

7

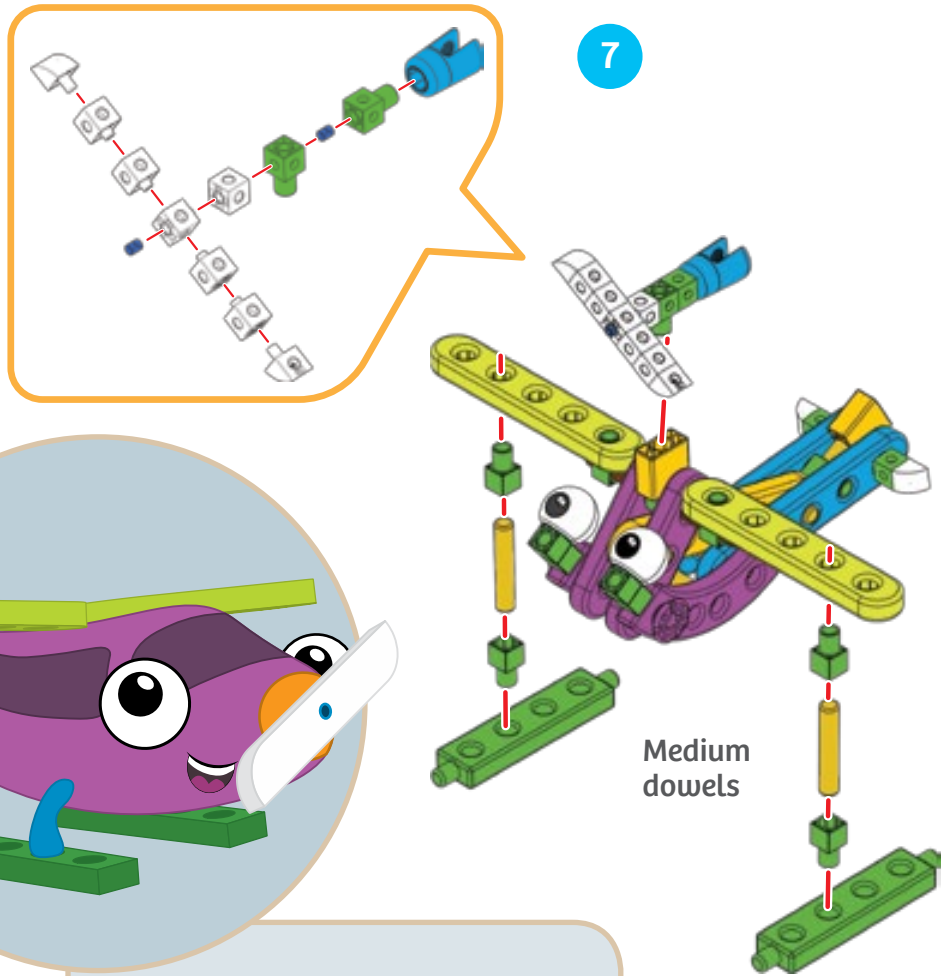

8

Done!

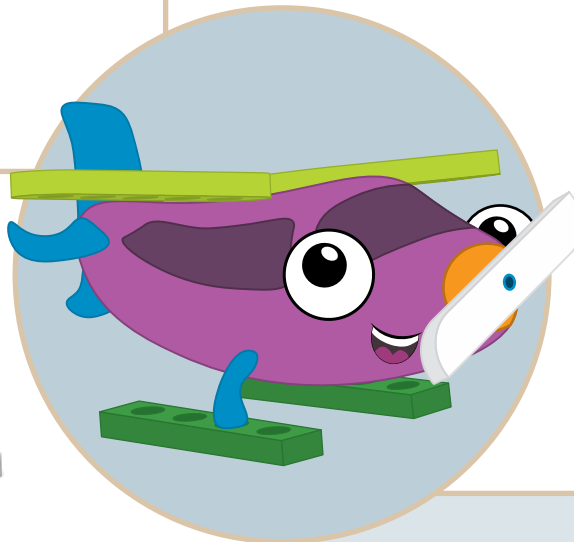
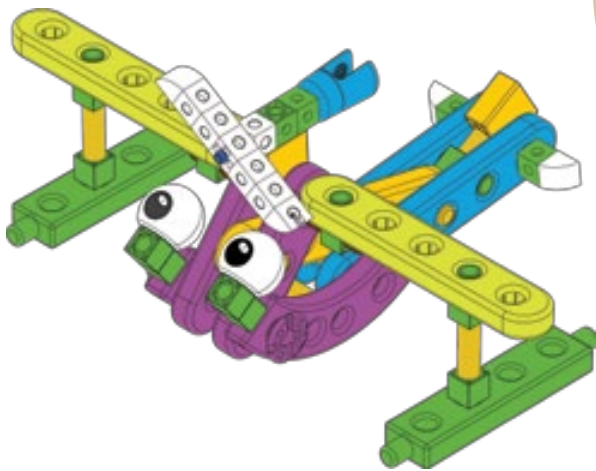

Cecile the Seaplane took off from the water's surface with ease. "My pontoons allow me to float on the water's surface just like a boat!"

Cecile flew Ty, Karlie, Huxley, and Remus back to the beach where Mr. and Mrs. O were standing at the edge of the water. They were talking to a large man with a big mustache.

“Welcome back kids!” Mr. O said. “Meet Mr. Shelly, the manager of the Beach Hotel. He has something he wants to ask you.”

“Hi, kids. The hotel is having a big barbecue tomorrow but we forgot to tell everyone! Can you think of a way to spread the

word across the whole island on such short notice?”

“I have the perfect solution,” Ty stated confidently. “Let’s build a propeller plane that can fly a banner behind it announcing the barbecue! The plane can fly around the whole island.”

Huxley began twirling around in excitement. He had always wanted to build a prop plane! Ty and Karlie got to work painting the banner.



PAULY THE PROPELLER PLANE

1

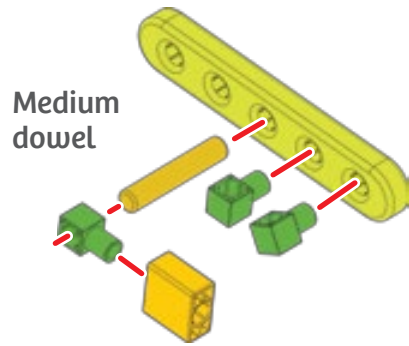

2

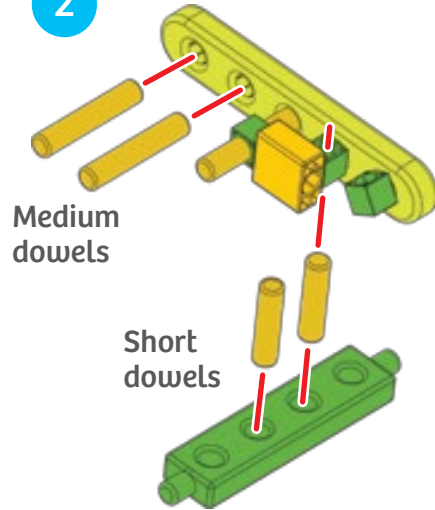

3

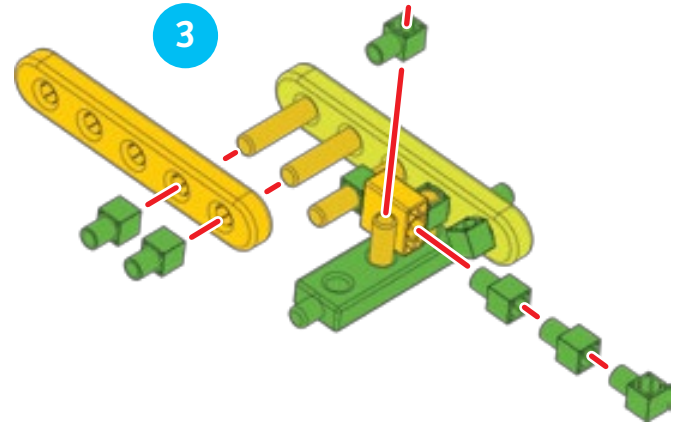

4

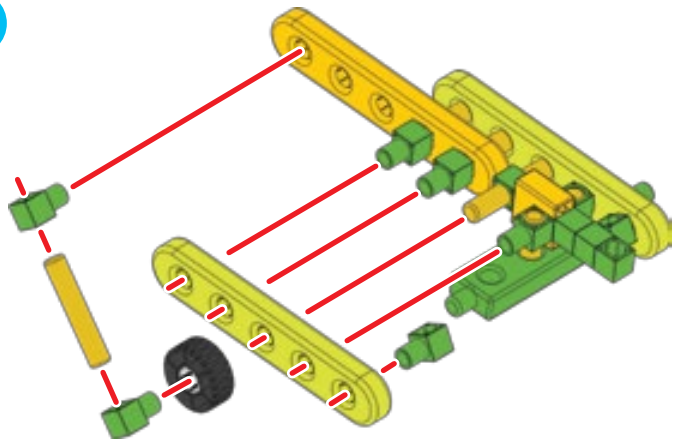

5

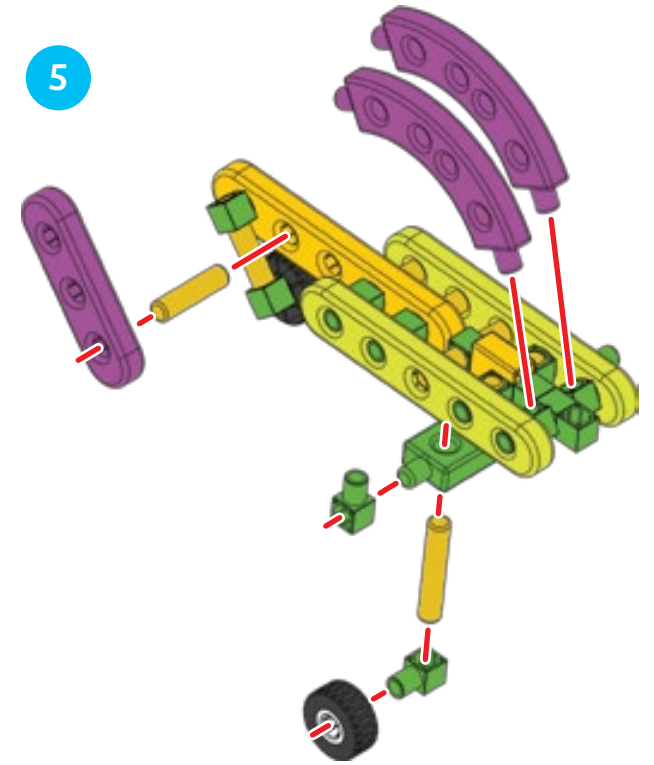

6

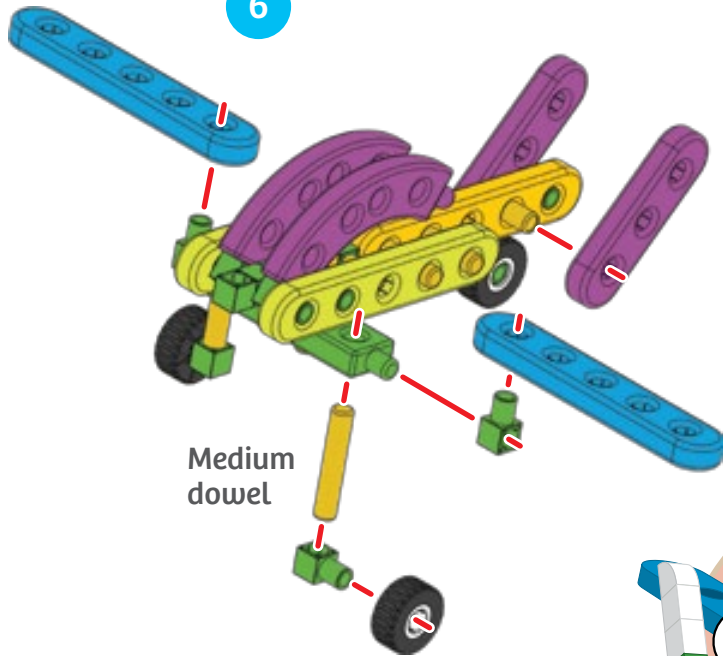

Medium dowel

7

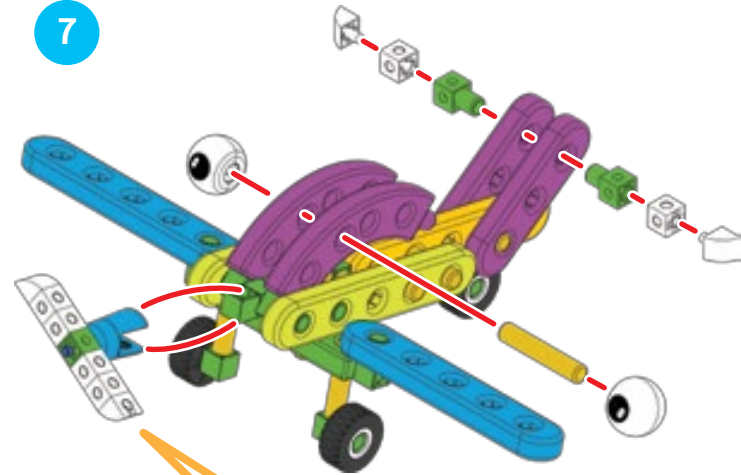

8

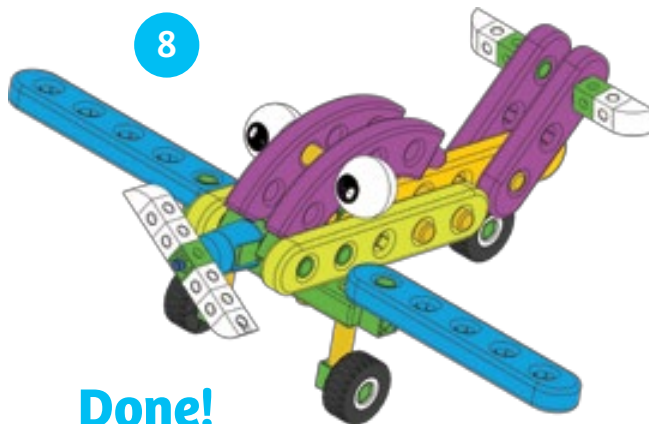

Done!

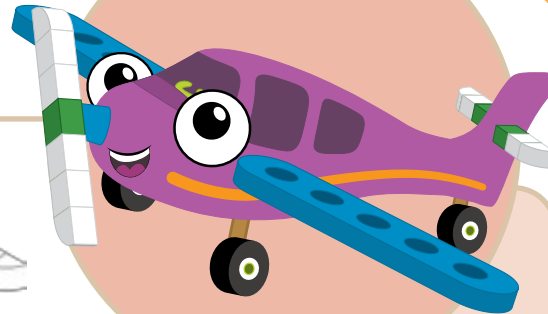

Pauly took off from the road next to the beach and unfurled the banner before flying around the whole island.

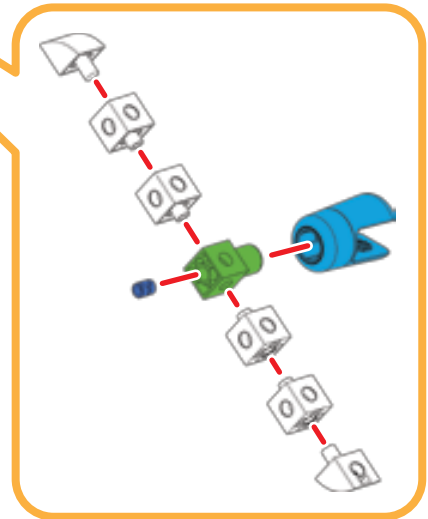



BBQ TOMORROW! BEACH HOTEL! ALL WELCOME!

Everyone on the beaches around the island saw the banner. They were all excited about the invitation to the party.

“Great work kids!” Ms. O declared. “This is going to be a great barbeque!”

“Nice job guys. What do you want to do next?” asked Mr. O.

“Ty and I want to go hang-gliding!” shouted Karlie.

Huxley looked nervous. Remus danced around in excitement.

“I think Huxley can help you do that,” Mr. O said. “Hux, can you build a hang glider?”

Huxley was already working out the plans for the hang glider design.

HANK THE HANG GLIDER

1

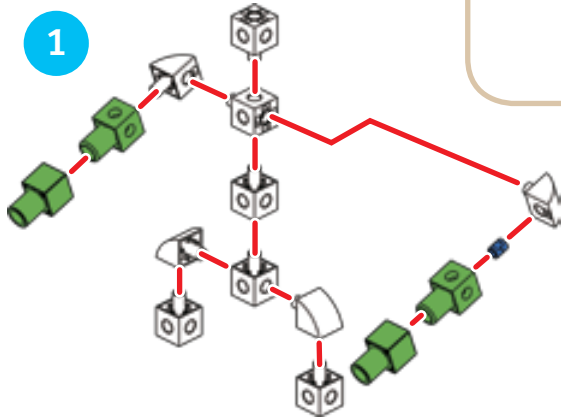

2

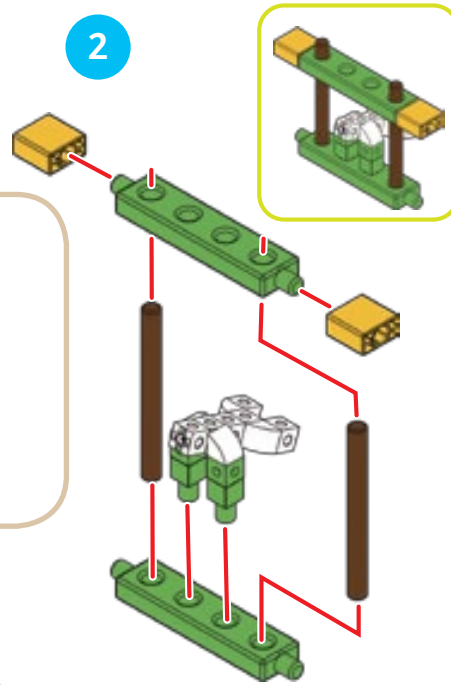

3

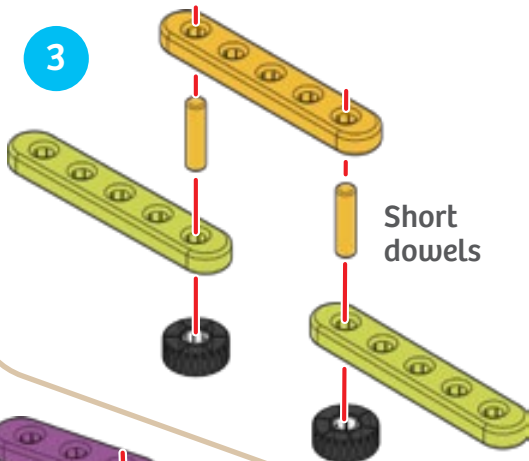

Short
dowels

4

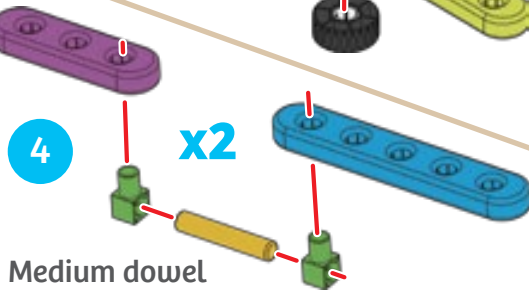

x2

Medium dowel

5

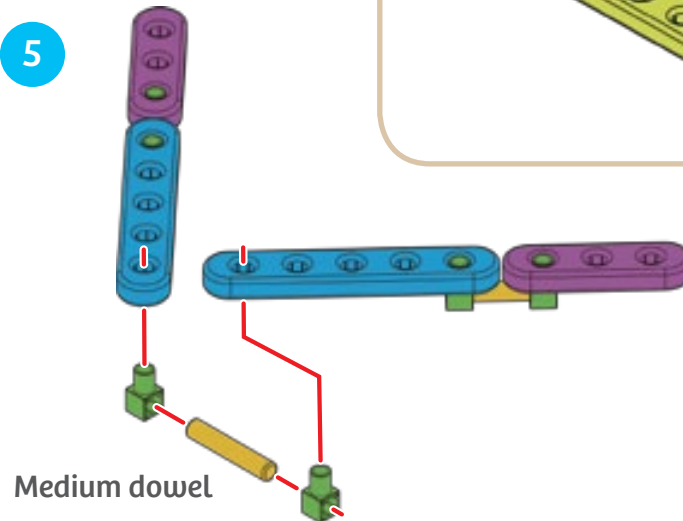

Medium dowel

6

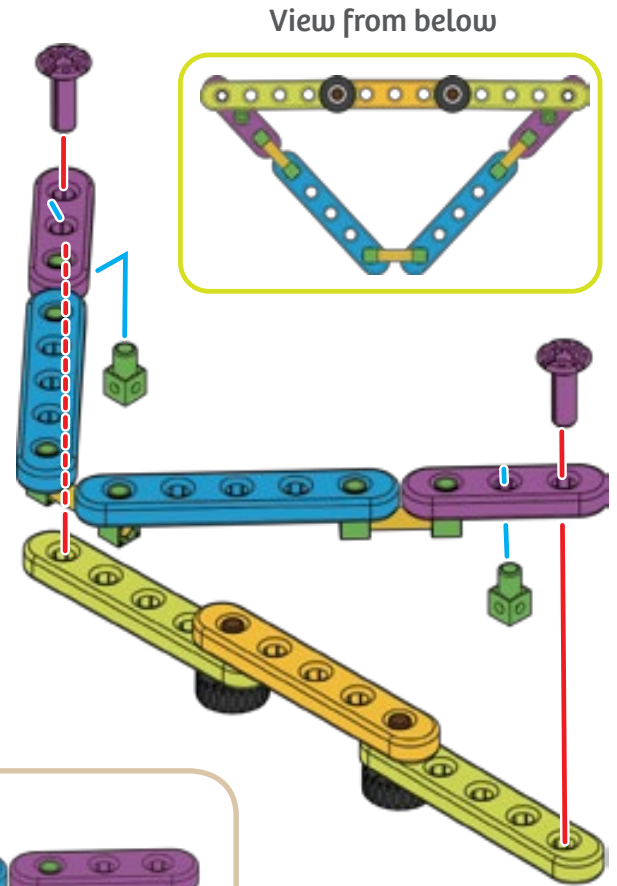

View from below

Continued >>>

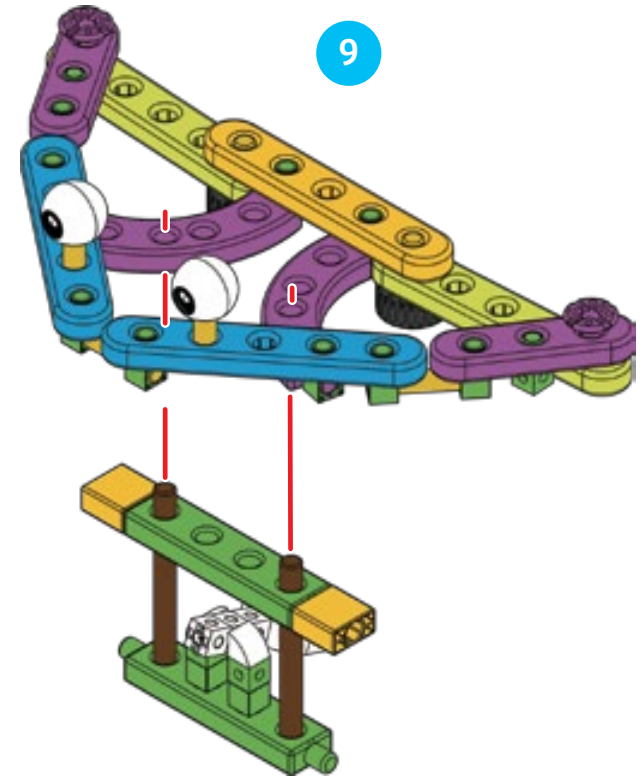
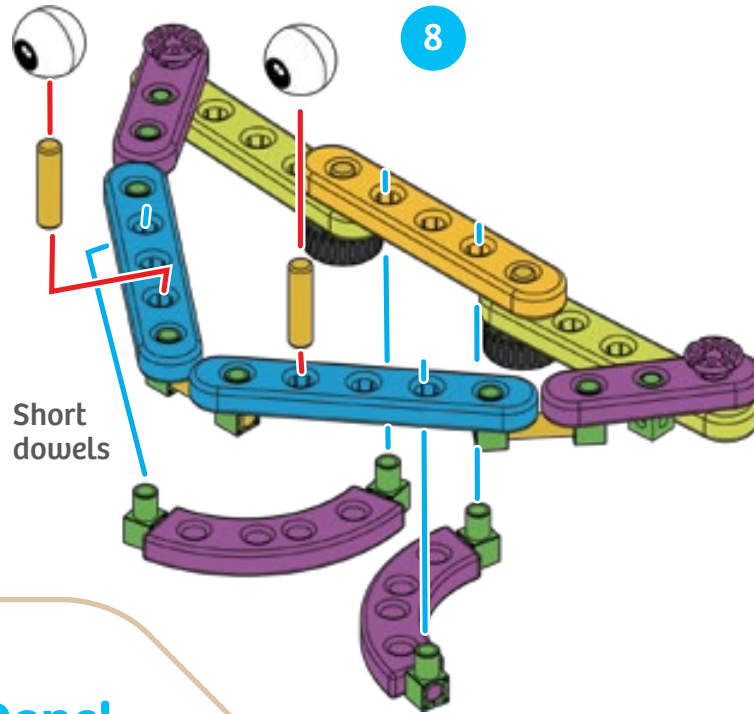
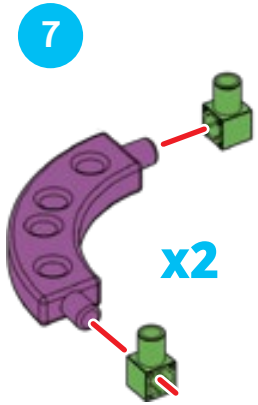

10 **Done!**

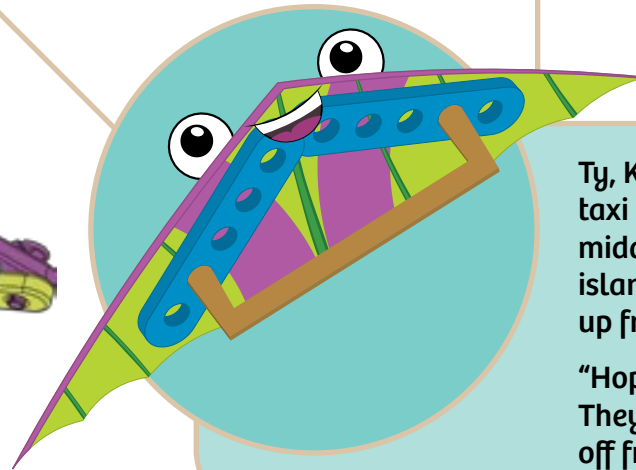
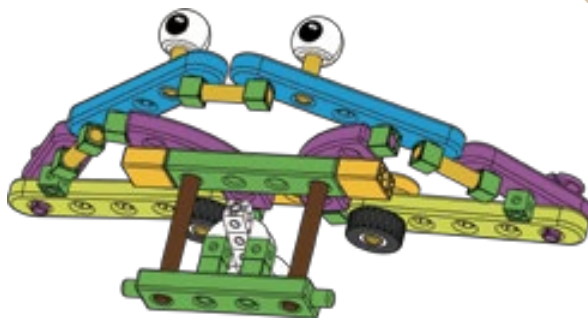

Ty, Karlie, Huxley, and Remus took a small taxi up to the top of the old volcano in the middle of the island. In fact, the whole island was created by a volcano that grew up from the ocean floor.

“Hop on and hold tight,” Hank told the kids. They squeezed into the hang glider and took off from the top of the volcano.

The hang glider was a little difficult to steer. They wanted to glide toward the beach, but strong winds blew them off course.

“Uh oh! We’re going to land in that fenced off airfield down there!” shouted Karlie.

“Looks like a NASA launch site,” suggested Ty. “Cooooool!”

Huxley put out his wheel for landing. Remus covered his eyes. They landed safely at the NASA base.





“Hey you! What are you doing in here?” a woman in a spacesuit asked curiously.

“We made a wrong turn somewhere up there,” Ty said jokingly while pointing to the sky.

“Are you an astronaut?!?” Karlie shouted. “Can you take us on a quick space flight, pretty please?”

“Yes, I’m Astronaut Allie. And I would take you, but our space transports are already in space,” responded Astronaut Allie.

“Well, that’s no problem. We’ll build the space plane. We just need YOU to fly it!” said Karlie.

They started building.

SAM THE SPACE PLANE

1

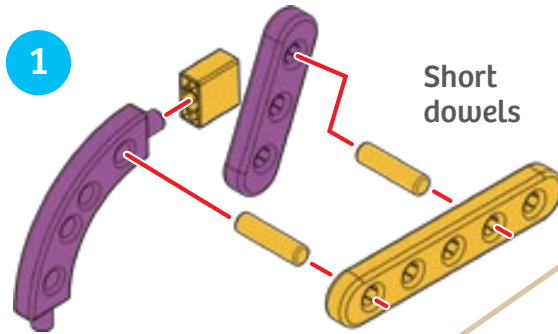

2

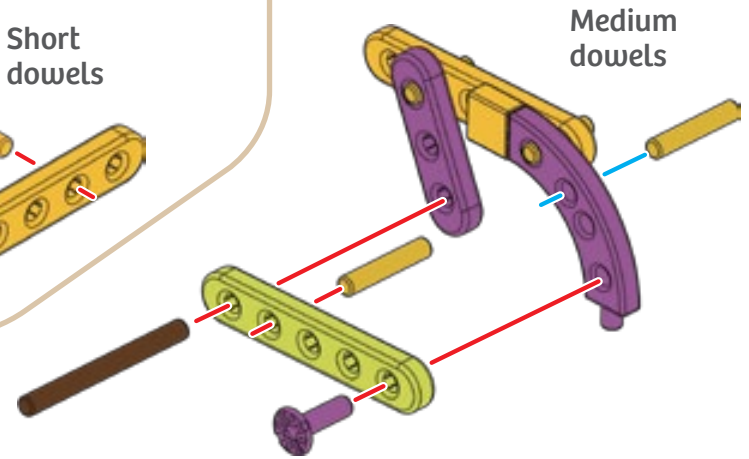

3

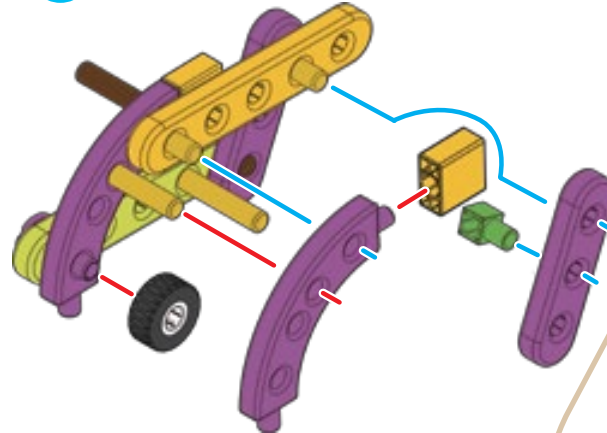

4

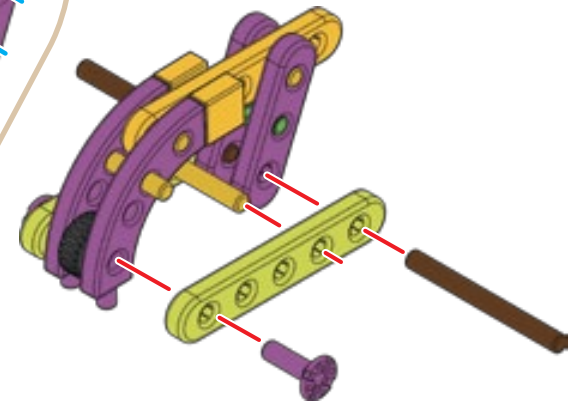

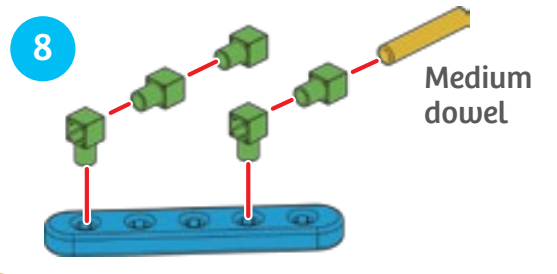
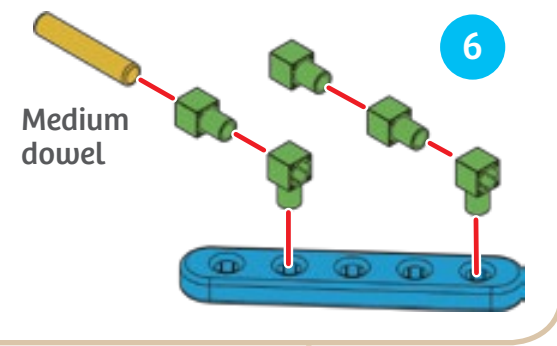
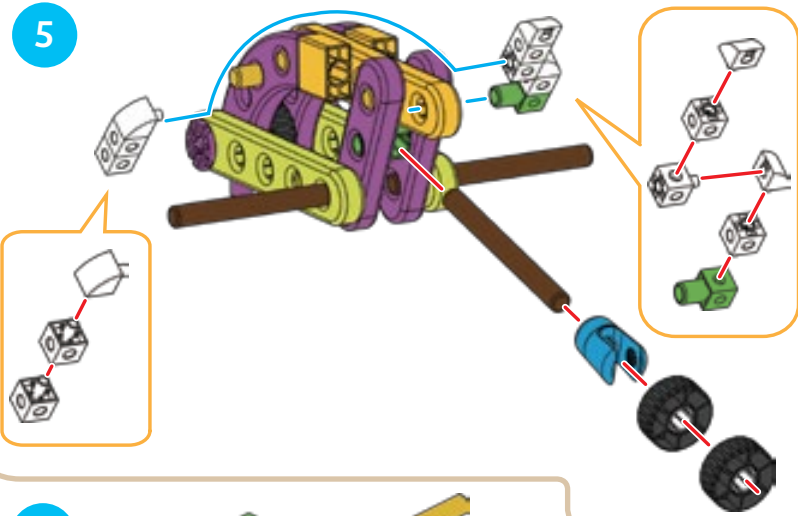

10
Done!

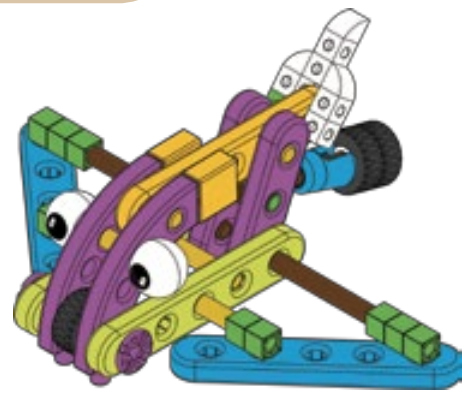
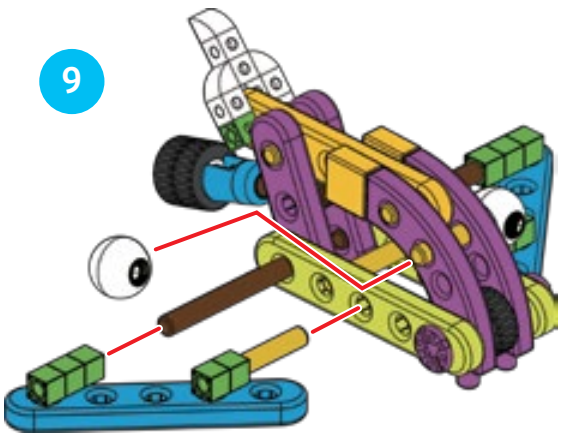
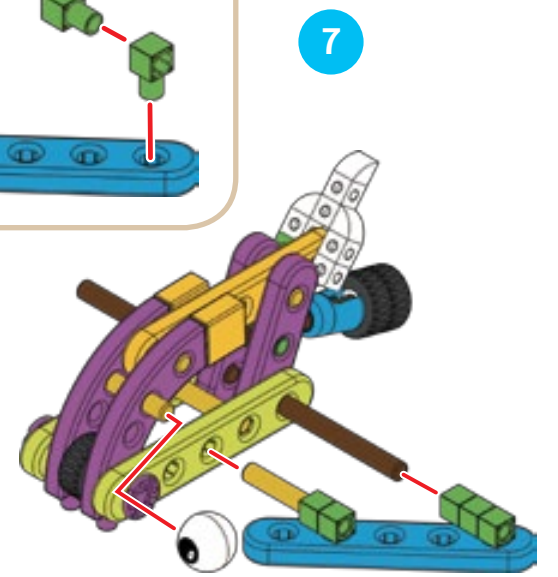

"3 ... 2 ... 1 ... Blast off!" Sam the Space Plane shouted as his engines fired up and he took off into space.

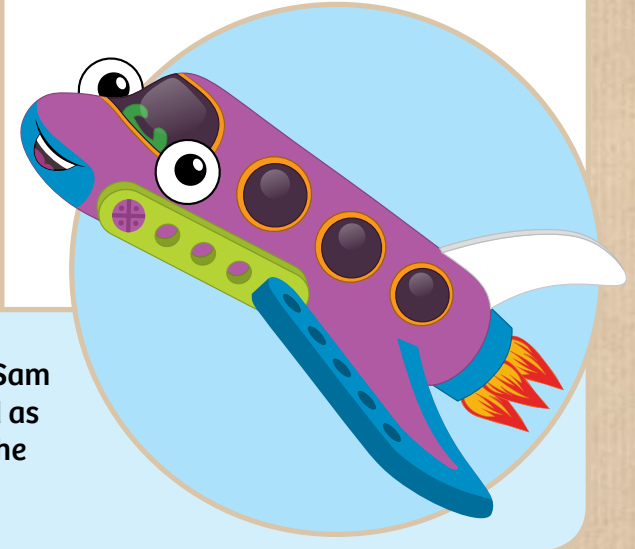

In no time they were orbiting Earth.

"I'm floating!" laughed Karlie. "This is so wonderful!"

"If you look down there, you can see the island we took off from, just off the tip of that big peninsula," said Astronaut Allie.

"Oh, that reminds me, we need to get back there ... the barbecue is probably starting soon!" reasoned Ty.

Sam took them back to Earth. They landed safely back at the airfield.

"How should we get back to the Beach Hotel? It's on the other side of the island," asked Ty.

"Huxley, can you build a solar glider so we can soar back to the beach? It's so sunny ... we could use the sun's energy to power the glider's rudders to steer us home," said Karlie.

Huxley was already wiring up solar panels by the time she finished her sentence. Then they assembled the glider.



GILDA THE SOLAR GLIDER

1

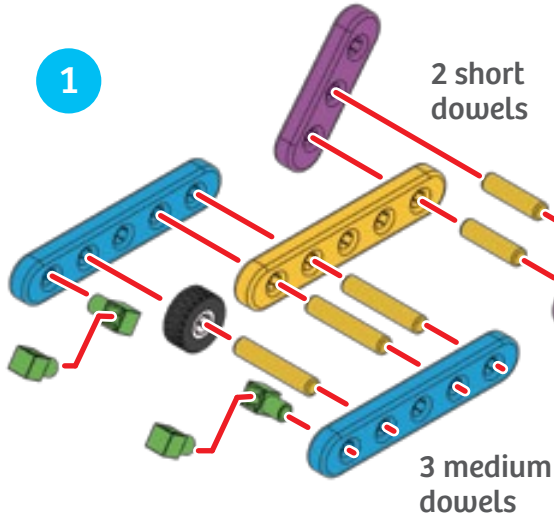

4

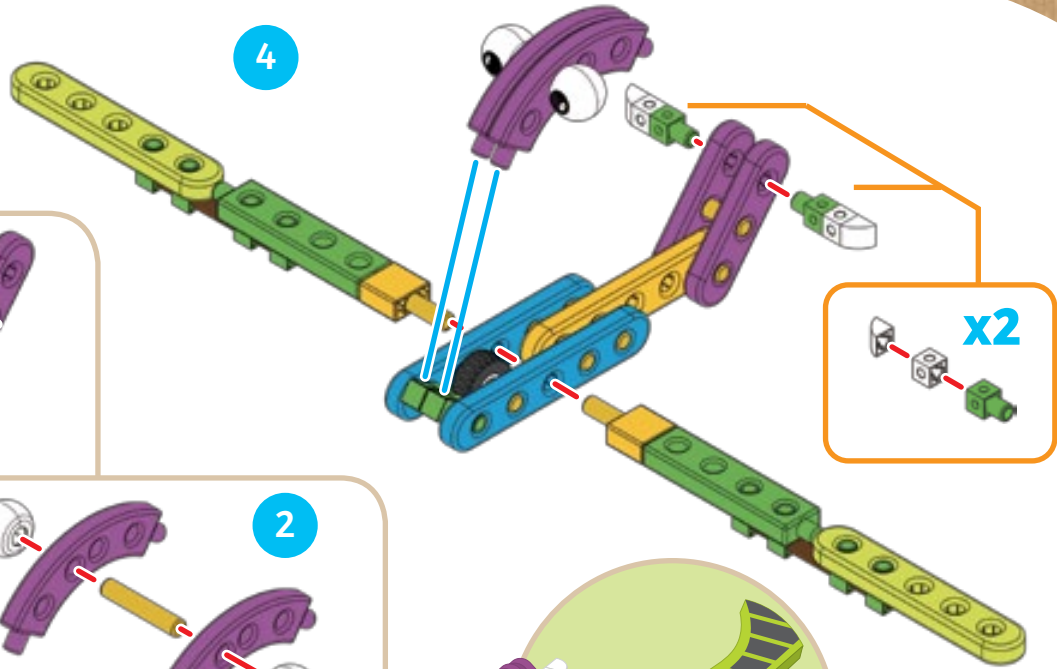

2

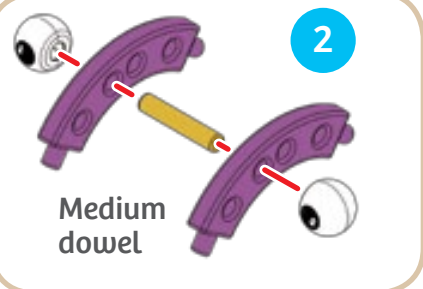

3

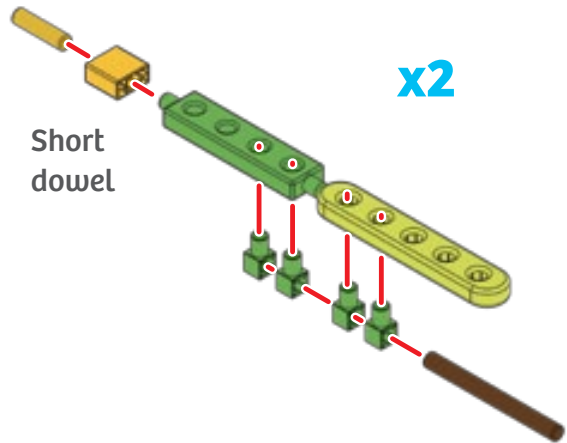

4

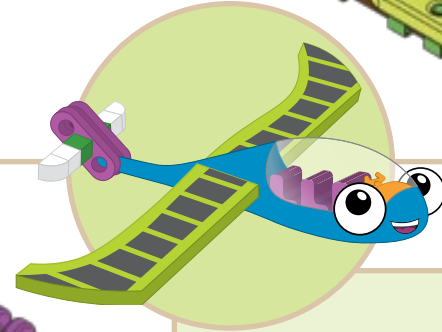

"Hi! I'm Gilda the Solar Glider," said Gilda. "The solar panels on my wings create electricity from sunlight. The electricity powers my small propeller but most of the time, I just glide. I can fold up my propeller and store it away while gliding!"

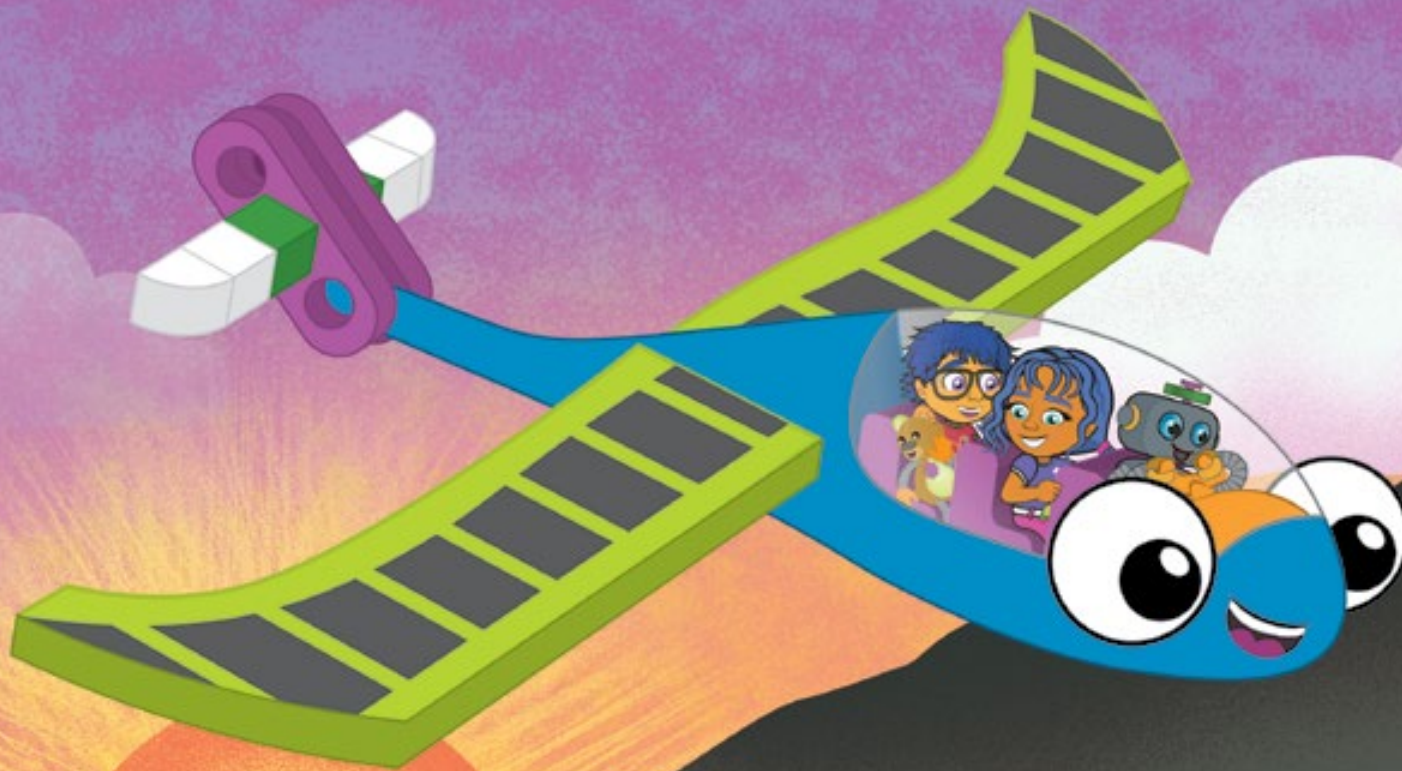

Gilda the Solar Glider took Karlie, Ty, Huxley, and Remus back to the beach hotel. The barbecue was just getting started. The flight was both peaceful and beautiful.

“Hey kids! How was OUTER SPACE!?!” Mr. O asked.

“Ah-maz-ing!” Ty responded. “Outer space is so cool.”

Karlie and Ty told their parents all about their adventure during the barbecue. There was music and dancing, and tables full of delicious foods. Everyone had a great time.

The Omega family stayed on the island for five more sunny

days. They went hiking, surfing, and swimming. They had picnics and, of course, built lots of fun things.

At breakfast on their last day, Mr. O said, “Well, it’s about time to go home. You have school and we have work.”

“Huxley, can you build us a biplane to take us home in style?” Ty asked. He had always wanted to fly in a biplane.



Everyone in the Omega family was sad to leave the island, but they were also excited to go home. They loaded their luggage and boarded the biplane.

Billy the Biplane took off and they started flying home.

Billy was a very slow plane and flew very low to the ground. The flight was fun, but it was taking a long time to get home.

“Hmmm ... maybe if we build a plane with three wings instead of two, we can get home faster?”

Billy landed smoothly. Huxley and the kids got to work building a triplane with three wings.

TRIP THE TRIPLANE

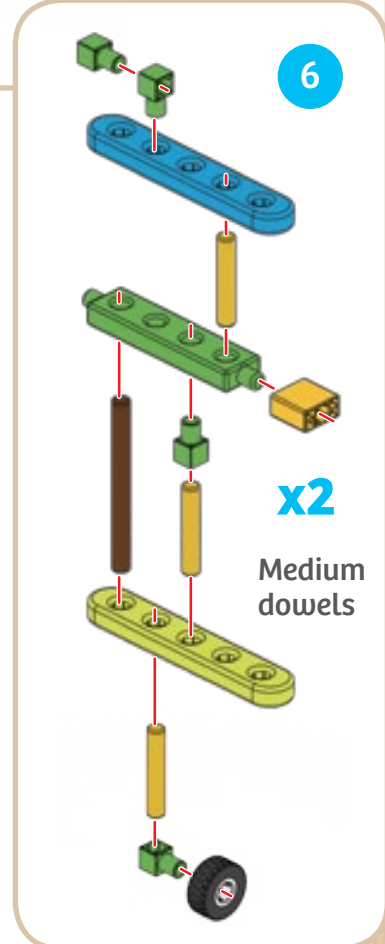
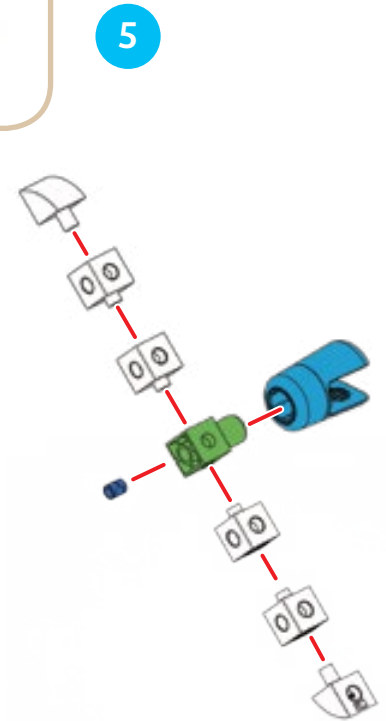
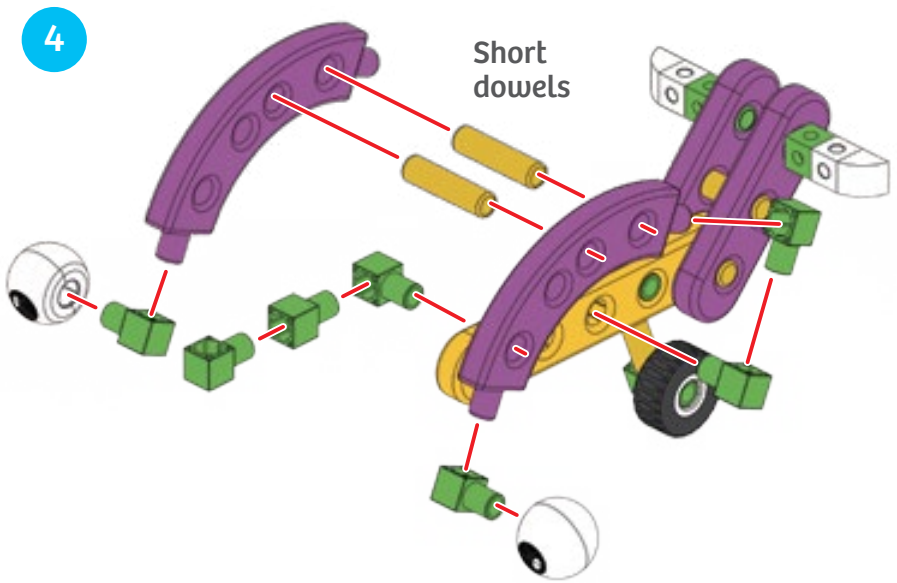
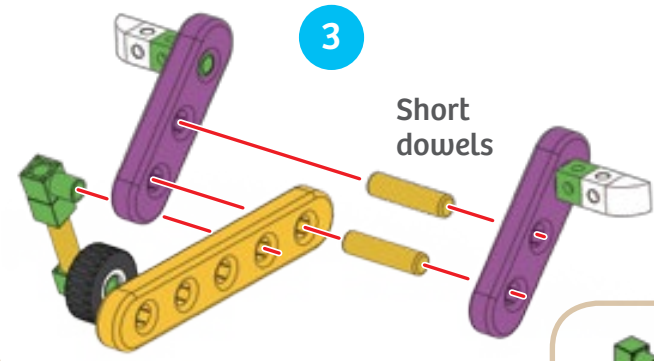
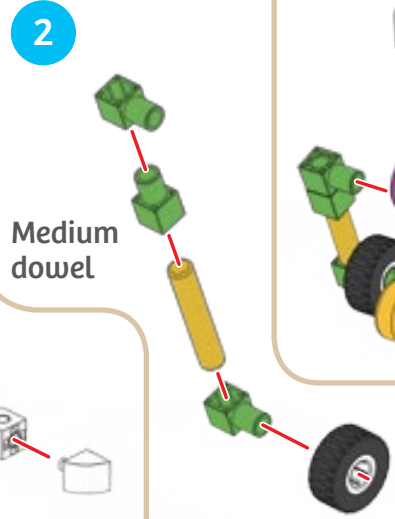
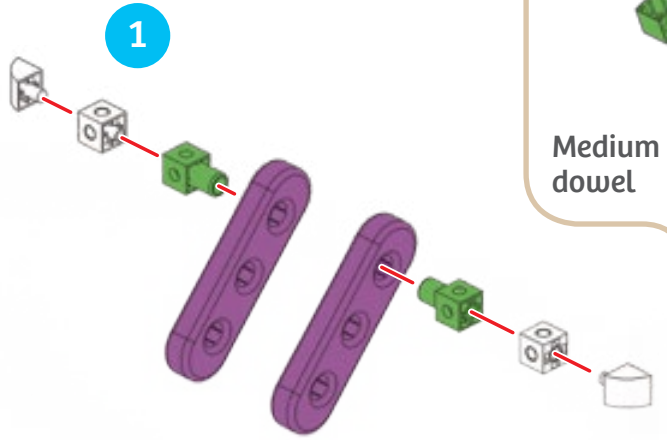

Continued >>>

7

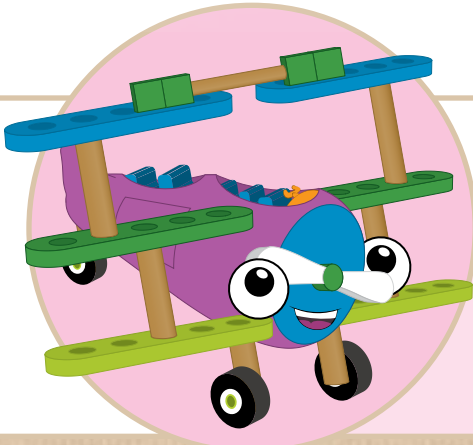
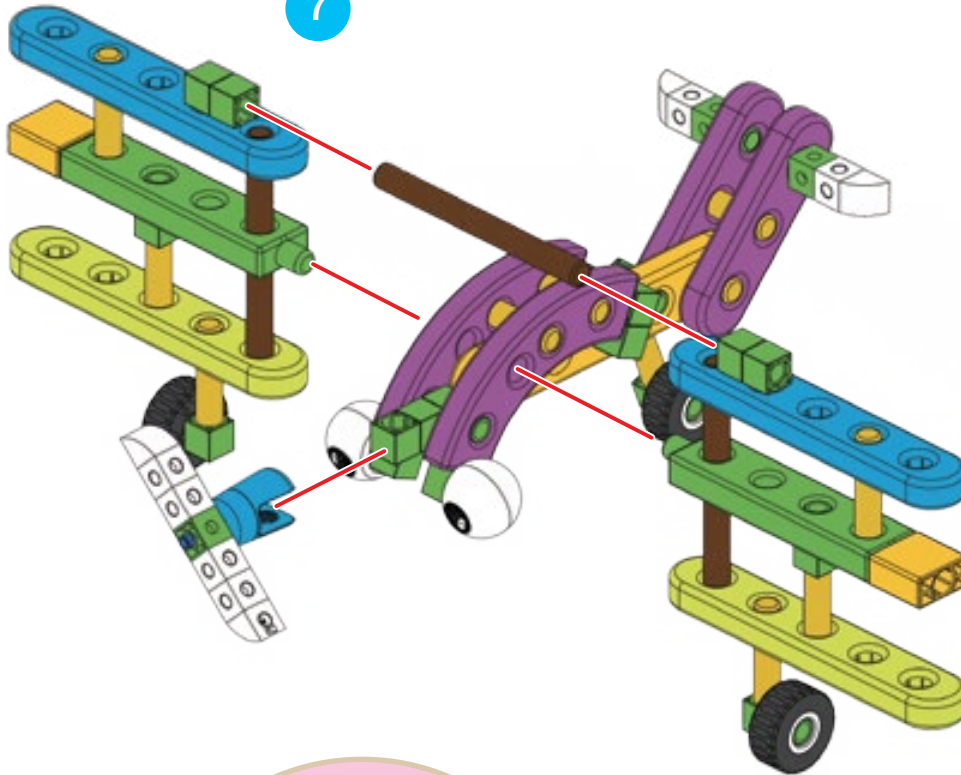

“Trip the Triplane at your service,” Trip stated politely. “I will take you back to Makersville.”

8

Done!

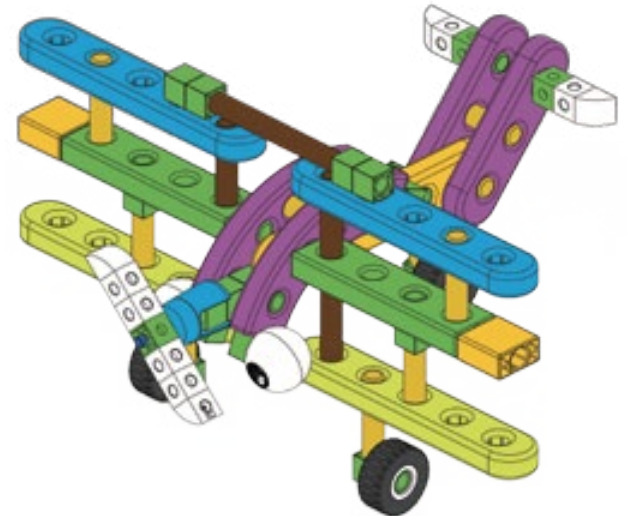



The Omega family boarded Trip and they took off. But Trip the Triplane was even slower than Billy the Biplane!

“Oops ... you know, with all these wings, I think there is a lot of drag slowing us down,” said Karlie.

“Oh, you’re right,” agreed Ty. “We don’t need more wings, we need a bigger engine!”

“YEAH!!” shouted Karlie. “Huxley, can you build us a supersonic jet plane with HUGE engines?!”

Huxley nodded and started designing a supersonic jet plane.



SCOOTER THE SUPERSONIC JET PLANE

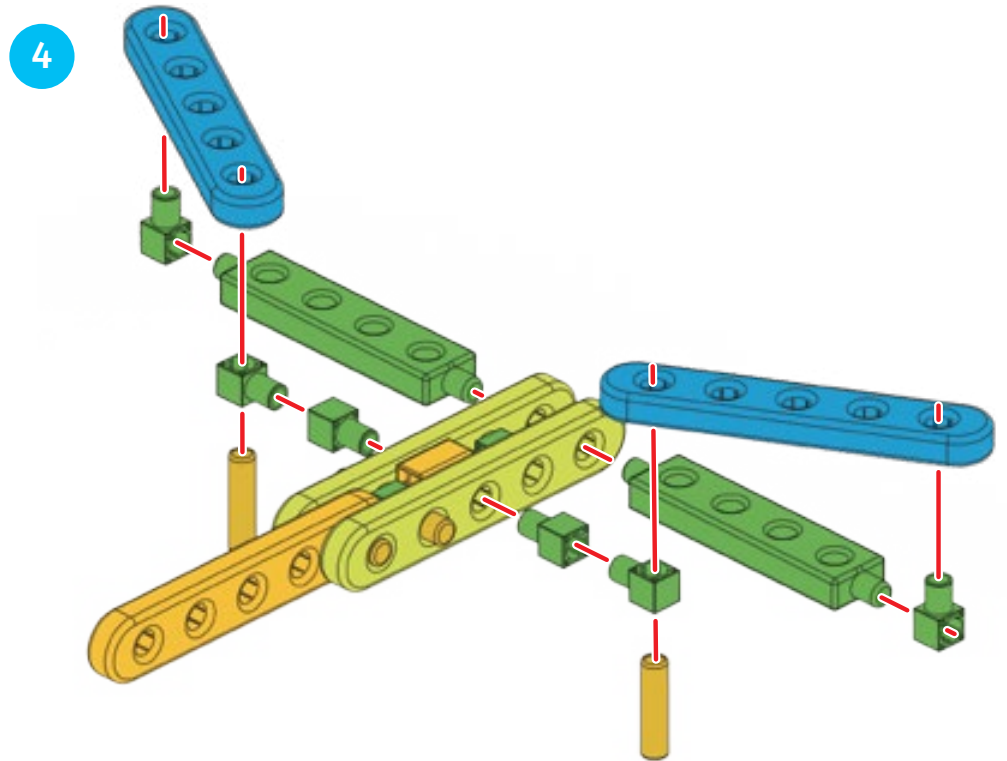
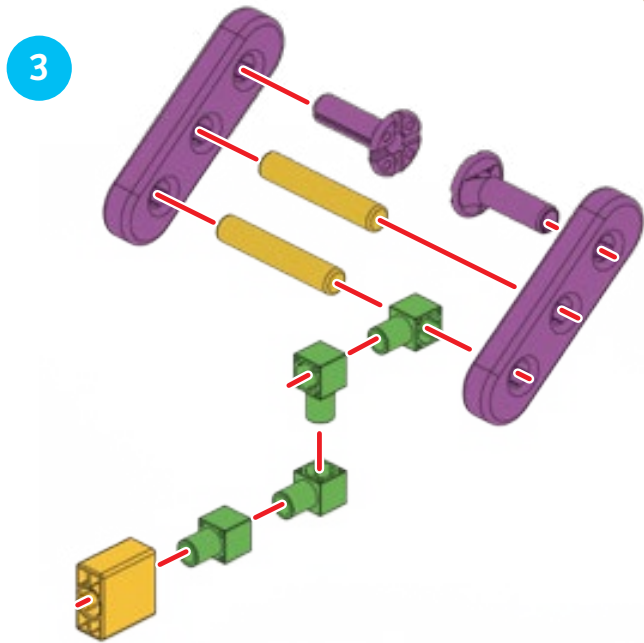
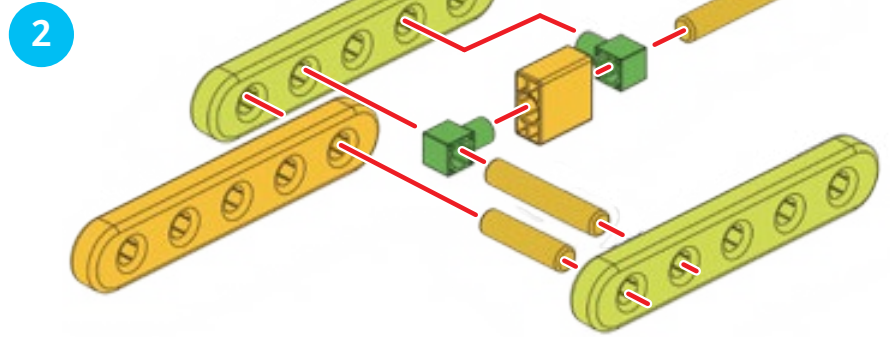
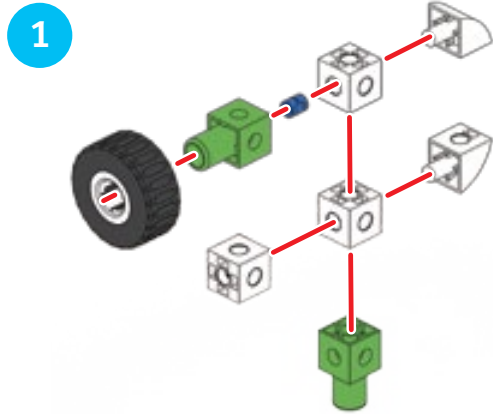

5

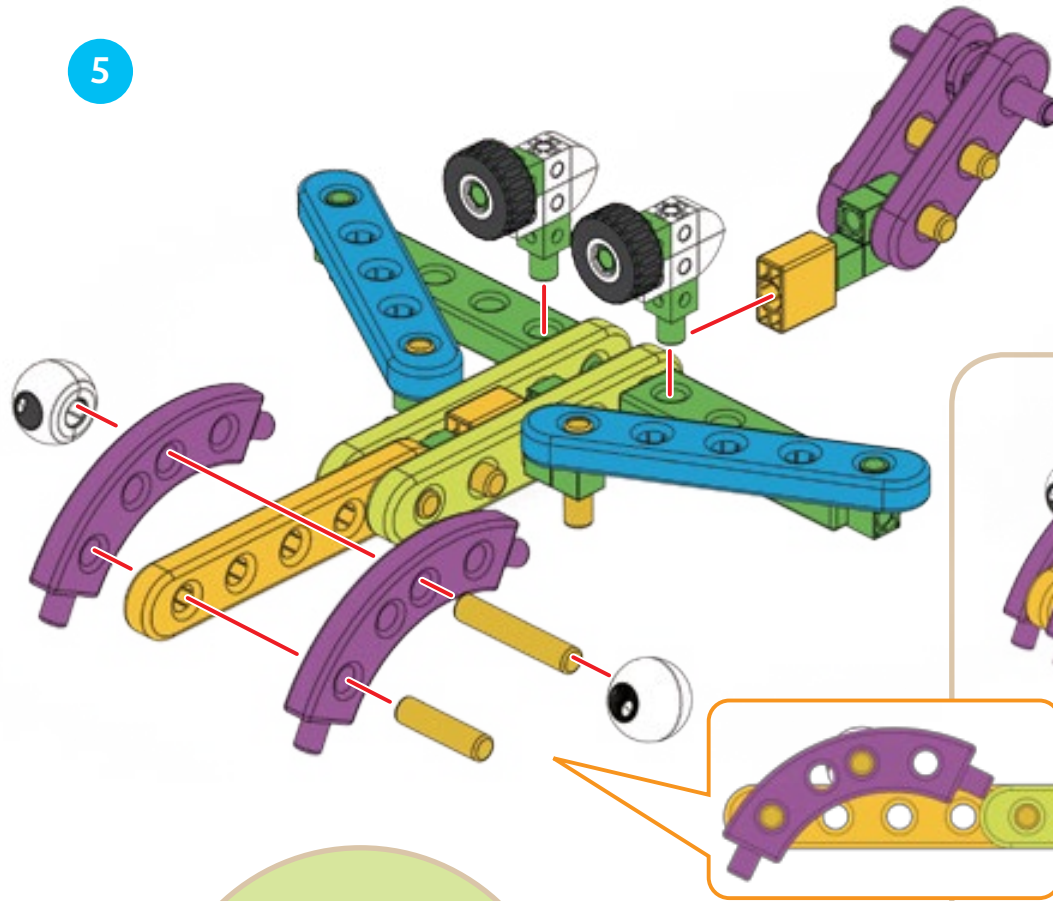

6



Done!

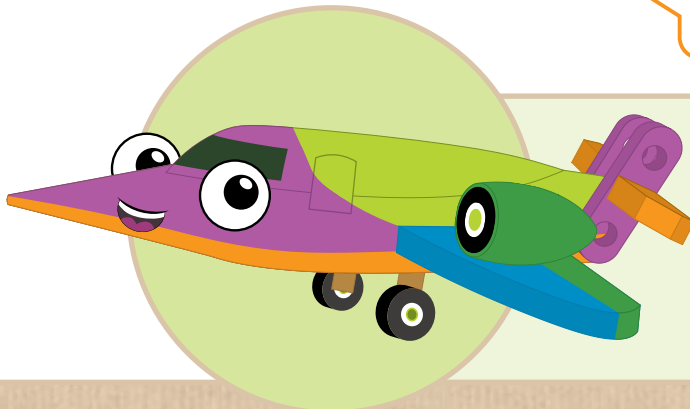

"Scooter the Supersonic Jet Plane at your service!" said Scooter. "I can fly faster than the speed of sound! My average speed is 20 times faster than a car driving on the highway."

"I'll get you home in no time!" Scooter the Supersonic Jet Plane declared. "My jet engines push air behind us so quickly that we move forward really fast!"

"Sounds great," said Ty. "I'm ready to be home! Can't wait to tell my friends about this trip!"

The flight took less than two hours to bring them home. Scooter touched down near the family's warehouse.

They thanked Scooter, disembarked the plane, and walked back home.

"Wow!" said Karlie. "This has been the most amazing vacation ever ... it's been ... out of this world!"

Everyone laughed.



1st Edition 2015 Thames & Kosmos, LLC, Providence, RI, USA
Thames & Kosmos® is a registered trademark of Thames & Kosmos, LLC.

This work, including all its parts, is copyright protected. Any use outside the specific limits of the copyright law without the consent of the publisher is prohibited and punishable by law. This applies specifically to reproductions, translations, microfilming, and storage and processing in electronic systems and networks. We do not guarantee that all material in this work is free from copyright or other protection.

Technical product development: Genius Toy Taiwan Co., Ltd., Taichung, Taiwan, R.O.C.
Text: Ted McGuire
Graphics and Packaging: Dan Freitas
Illustrations: Dan Freitas and Ashley Greenleaf

Manual assembly instruction diagrams: Genius Toy Taiwan Co., Ltd., Taichung, Taiwan, R.O.C., and Thames & Kosmos
Photos: Genius Toy Taiwan Co., Ltd., Taichung, Taiwan, R.O.C., and Thames & Kosmos

The publisher has made every effort to locate the holders of image rights for all of the photos used. If in any individual cases any holders of image rights have not been acknowledged, they are asked to provide evidence to the publisher of their image rights so that they may be paid an image fee in line with the industry standard.

Distributed in North America by Thames & Kosmos, LLC, Providence, RI 02903
Phone: 800-587-2872; Web: www.thamesandkosmos.com

Distributed in United Kingdom by Thames & Kosmos UK, LP, Goudhurst, Kent TN17 2QZ
Phone: 01580 212000; Web: www.thamesandkosmos.co.uk

We reserve the right to make technical changes.

Printed in Taiwan / Imprimé en Taiwan

