

**GEEK
& CO.
SCIENCE!**



PROJECT KIT **Ages
8+**

RuBBer BaND RACERS



THAMES & KOSMOS



Franch-Kosmos Verlags-GmbH & Co. KG, Pfizerstr. 5-7, 70184 Stuttgart, Germany | +49 (0) 711 2191-0 | www.kosmos.de
Thames & Kosmos, 301 Friendship St., Providence, RI, 02903, USA | 1-800-587-2872 | www.thamesandkosmos.com
Thames & Kosmos UK Ltd, Goudhurst, Kent, TN17 2QZ, United Kingdom | 01580 212000 | www.thamesandkosmos.co.uk

Safety information

WARNING. Not suitable for children under 3 years. Choking hazard — small parts may be swallowed or inhaled.

Keep the packaging and instructions as they contain important information.

WARNING. Do not aim at eyes or face.

WARNING. Do not fly close to the eyes or face.

Do not throw the models toward other people or animals. Make sure people and animals are well out of the potential flight path of the flying models.

Flying models should be used in an open area with a 30-meter radius containing no people or animals.

A parent or other adult should supervise all outdoor experiments with the models. Outdoor experiments should not be conducted near streets.

Do not touch the rotating rotor.

Be careful that loose clothing or hair does not get caught in the rotor.

Wear eye protection to avoid injury to the eyes.

WARNING! Use the model boats only in shallow water and under adult supervision.

Be careful when inserting the wooden dowels into the plastic components. If you put too much force on them, they can warp, splinter, or break. Do not injure yourself!

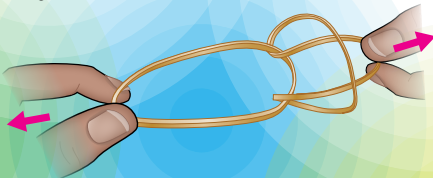

Working with bamboo

Bamboo is a super strong natural material. The thickness of the bamboo dowels can vary, as the material can be affected by humidity and other factors. When working with the bamboo dowels, you may find that some of them do not slide easily into the airfoil ribs or other plastic connectors. If a bamboo dowel does not slide smoothly into a connector, try the other end of the dowel or a different bamboo dowel. We have included a piece of sandpaper: With the sandpaper, you can sand down the bamboo dowel to reduce its thickness. We have also included extra bamboo dowels in case one does not work.

Part separator tool

Use the part separator tool to help you separate small parts.

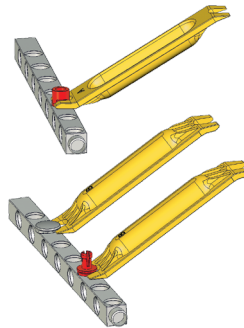

The end marked "A" can be used to remove anchor pins.

The end marked "B" can be used to remove button pins and shaft plugs.

Tip! If the rubber bands in your kit ever break or wear out, you can use **regular-size rubber bands** from around the house. To make them long enough, simply loop two of them together like this and then pull apart to tighten.

KIT CONTENTS

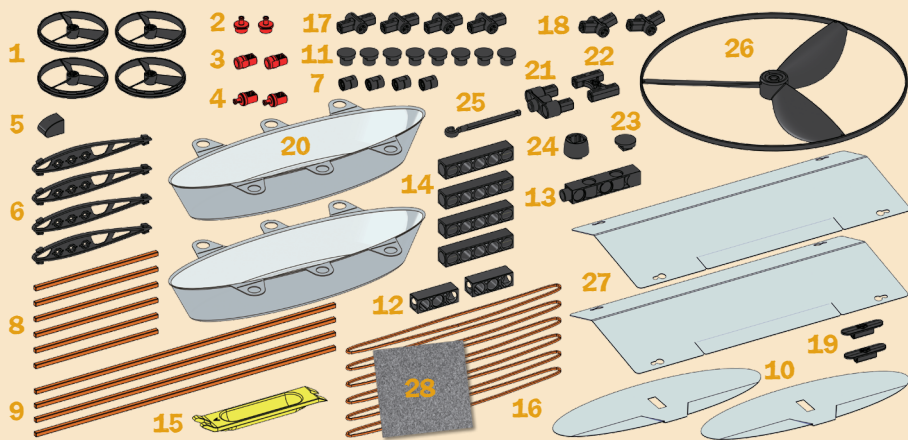

- | | | | |
|----|------------------------------|----|-------------------------------|
| 1 | Wheels (4) | 15 | Part separator tool |
| 2 | Shaft plugs, short (2) | 16 | Rubber bands (6) |
| 3 | Dowel holder anchor pins (2) | 17 | Straight connectors (4) |
| 4 | Dowel holder shafts (2) | 18 | 150-degree connectors (2) |
| 5 | Nose piece | 19 | Stabilizer connectors (2) |
| 6 | Airfoil ribs (4) | 20 | Hulls (2) |
| 7 | Dowel holder pegs (4) | 21 | Hook fixture |
| 8 | Bamboo dowel, 90 mm (6) ① | 22 | Bridge connector |
| 9 | Bamboo dowel, 220 mm (4) ② | 23 | Propeller cap |
| 10 | Stabilizer films (2) | 24 | Propeller cone |
| 11 | Button pins (8) | 25 | Rubber band hook |
| 12 | 3-hole rods (2) | 26 | Propeller |
| 13 | 5-hole dual rod | 27 | Wing surface plastic film (2) |
| 14 | 5-hole rods (4) | 28 | Sand paper |

YOU WILL ALSO NEED: A “test flying” area at least 30 meters (about 100 feet) long, and a tub or kiddie pool for the watercraft experiments

Hey Rubber Bandits!

Ready to build five awesome rubber band powered models, learn how propellers push vehicles forward, and how rubber bands store energy? Well, let's get started! With this kit you can build an airplane, helicopter, fan car, airboat, and hydrofoil. Helo the Geeker will be your guide!

Hi! I'm Helo!



PART 1

PROPELLERS FOR FLYING

Up! Up! And away!
Let's take off!



Model 1: Airplane

- 1 Assemble the propeller.

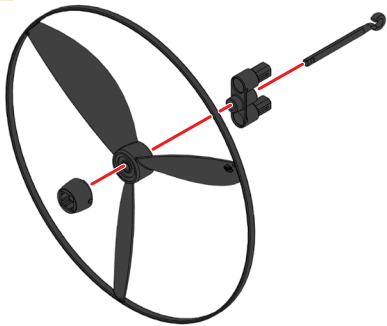

The logo should be facing away from the hook for this model.

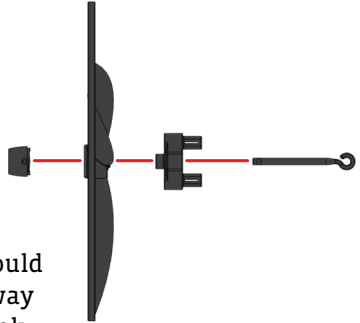

- 2 Put the cap on the propeller.

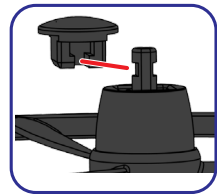
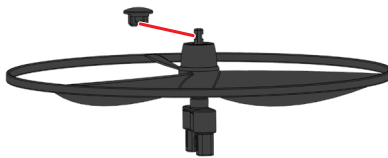

- 3 Assemble the fuselage as shown using two 220 mm dowels 2 and 3-4 rubber bands.

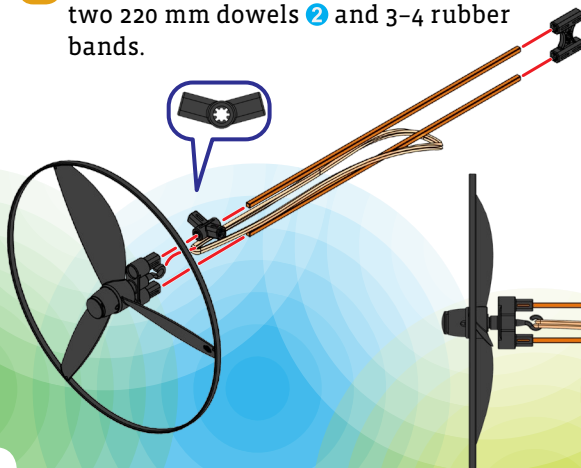

Note! If a dowel does not slide smoothly into a connector, use the sandpaper to sand down the dowel to reduce its thickness. Slide the sandpaper back and forth along the part of the dowel that you want to sand down, and test it often until it fits.

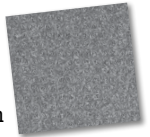

Use 3-4
rubber bands.

- 4 Wrap the rubber bands around the bridge connector.



- 5 Assemble the right-side wing with a 220 mm dowel 2, two airfoil ribs, a straight connector, and a wing surface film.

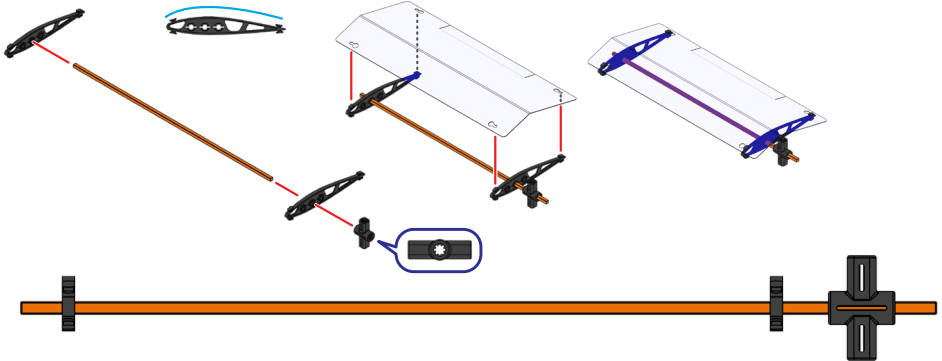

- 6 Attach the wing surface to the airfoil rib by fitting the holes over the small tabs on the airfoil rib.

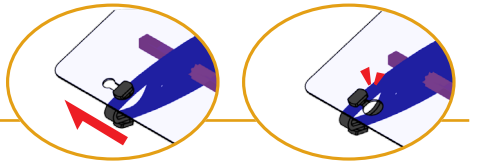

- 7 Assemble the left-side wing as a mirror image of the right-side wing.

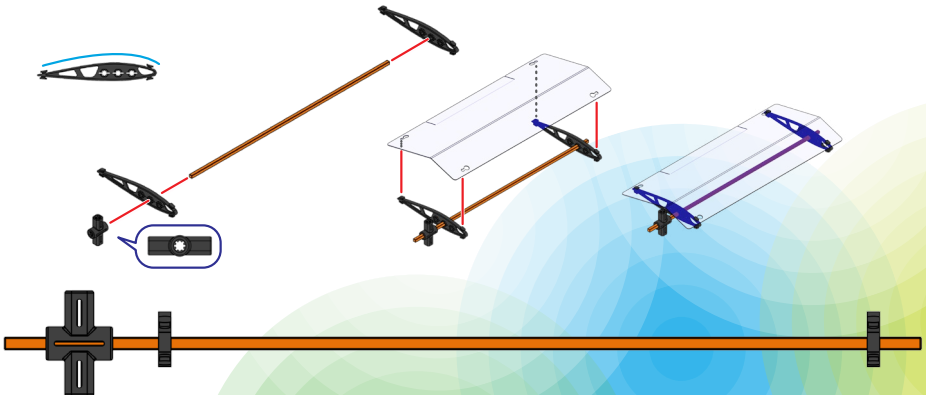

- 8 Attach the stabilizer films to the tail section using a 90 mm dowel ①.

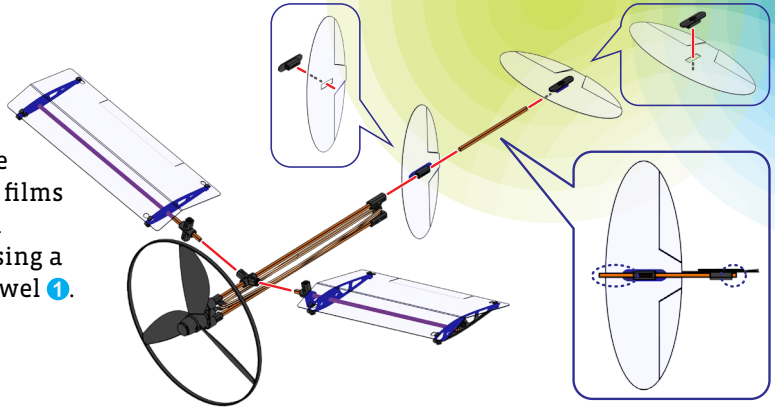

- 9 Build both landing gear assemblies with a 90 mm dowel ①, dowel holder shaft, and a wheel. Affix the landing gear to the fuselage.

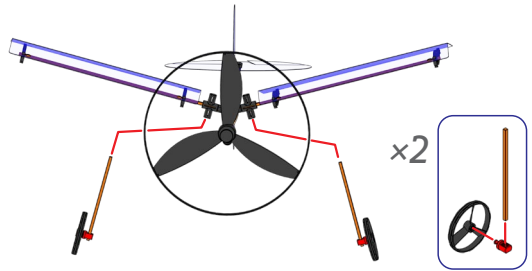

- 10 To fly the plane, make sure all components are securely assembled, nothing is twisted, and the two sides are symmetrical. Take the model to an open space with a 20-meter-long “test flying” area. Grass or smooth flooring is preferable to keep your model safe upon landing.

Wind the rubber bands by turning the propeller in the direction indicated. Wind it 80–100 times. Hold the model by the fuselage dowel and hold the propeller to keep it from unwinding. Throw the plane forward with a smooth flick of the wrist and simultaneously let go of the propeller. The plane will fly forward!

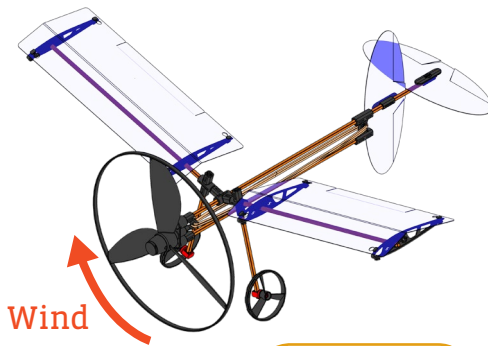

Wind 80–100 rotations.

Make adjustments — such as sliding the wings backward or forward and tilting the stabilizer rudders — until you get it to fly nicely! Try winding the rubber bands differing numbers of times.

Model 2: Helicopter

- 1 Assemble the propeller.

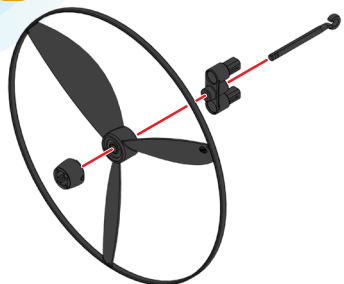

The logo should be facing away from the hook for this model.

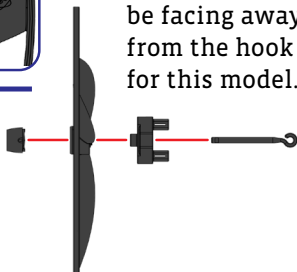

- 2 Put the cap on the propeller.

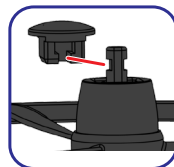
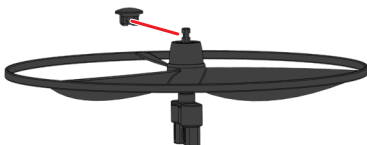

- 3 Assemble the rotor mast as shown using two 220 mm dowels ② and 4 rubber bands.

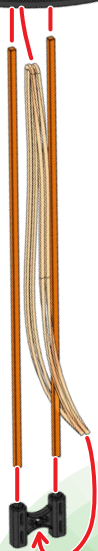
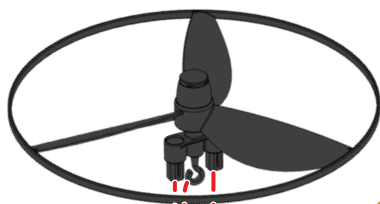

Use 4 rubber bands.

- 4 Attach the stabilizer films to the tail section using 90 mm dowels ①.

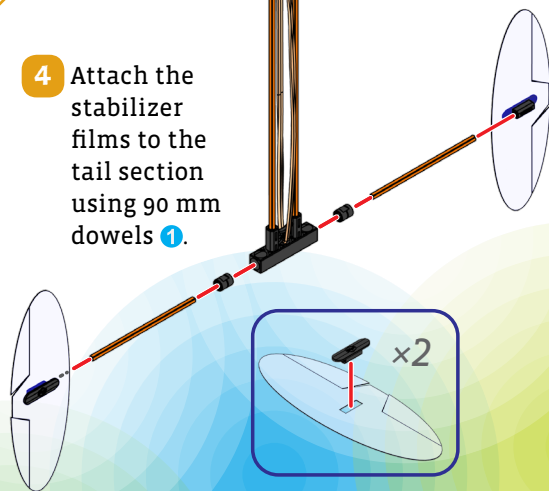
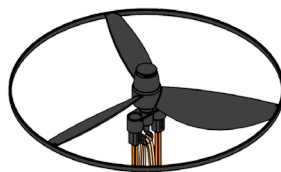

- 5** Build the landing gear assembly with 90 mm dowels **1** as shown.

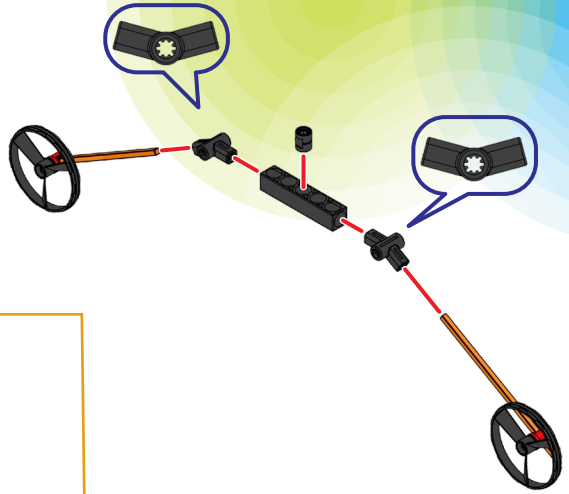
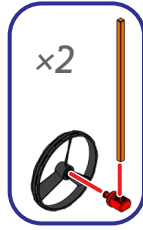

- 6** Attach the landing gear to the helicopter body.

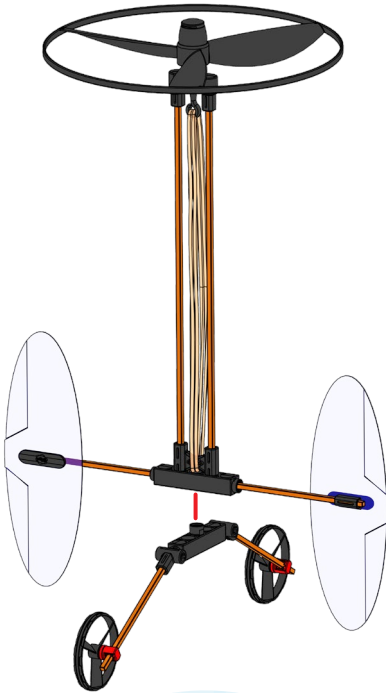

Wind

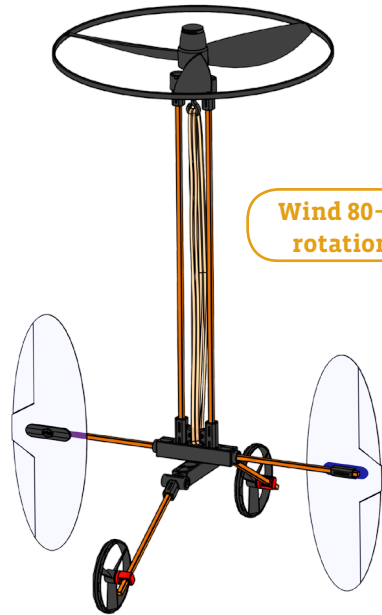

Wind 80-100 rotations.

- 7** Fly the helicopter outside or in a space with very high ceilings. To fly, wind the propeller in the direction indicated. Wind it 80-100 times. Hold the propeller. Do not stand over the helicopter.

Release the propeller and the model will fly upward and then fall back down. Be careful that no one is hit when it flies up or falls down.

HOW DO PROPELLERS WORK?

This is so Cool
it makes my
head spin!



To understand how propellers work, let's first look at another part of the airplane: the **wing**. Wings generate a lifting force in **air**. Air is a mixture of gases. The molecules in air are always moving around and they are always being pulled toward Earth by gravity. **Air pressure** is the result of all these moving particles pushing on each other and all the things under and around them.

Air behaves like a **fluid** and obeys the physical laws of fluids. To understand how wings work, the most important principle of fluids to know is that the faster fluids move, the lower their pressure. This is called **Bernoulli's principle** after the scientist who came up with it. Airplane **wings** are designed to take advantage of Bernoulli's principle to lift a plane upward.

The cross section of a wing has a top surface that is curved and therefore longer than its bottom

surface. Air flowing over the top has to travel farther, so it moves faster. As Bernoulli's principle states, faster moving air has a lower pressure and slower moving air has a higher pressure. The high air pressure under the wing pushes the wing upward and the low pressure above sucks it upward. This is called **lift**. Lift is always perpendicular to the direction of the airflow.

A **propeller** works like a spinning wing. Imagine taking two (or more) wings, sticking them on a central axis opposite one another, and spinning the axis. The wings would spiral through the air and create low pressure in front of them and high pressure behind them, and thus pull the propeller forward. The wings of a propeller, called **blades**, are angled so they cut into the air more.

Just like they screw through the air, propellers can also work in another fluid: water!

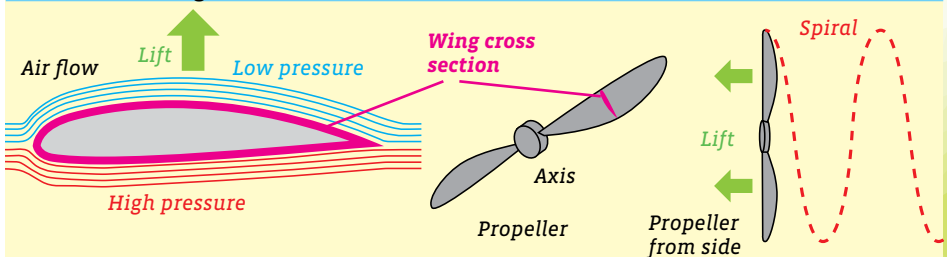

PART 2

PROPELLERS FOR DRIVING

I'm a racing fan... in more ways than one!



Model 3: Fan car

- 1 Assemble the propeller.

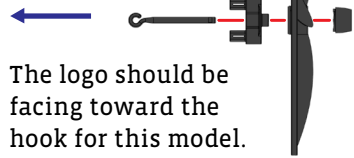
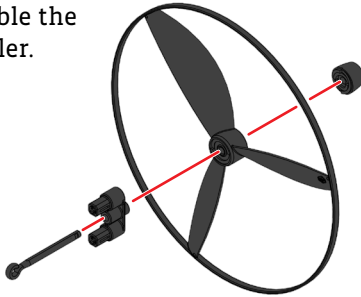

- 2 Put the cap on the propeller.

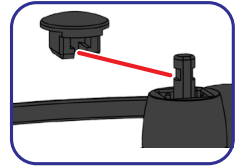
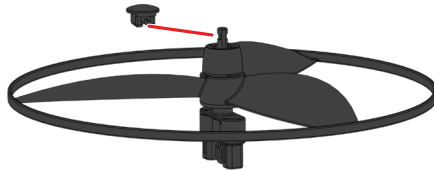

- 3 Start the chassis assembly as shown using a 220 mm dowel 2.

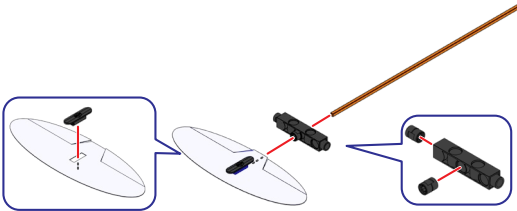

- 4 Continue the chassis assembly as shown using another 220 mm dowel 2.



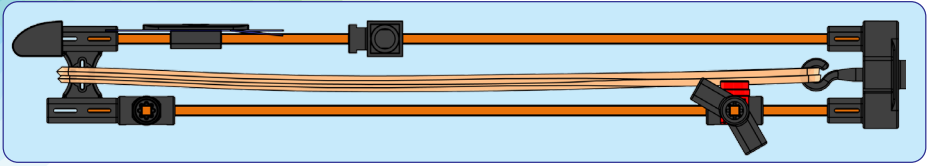

- 5** Connect the upper and lower chassis dowels together with the propeller, 2-3 rubber bands, bridge connector, and nose piece.

Use 2-3 rubber bands.

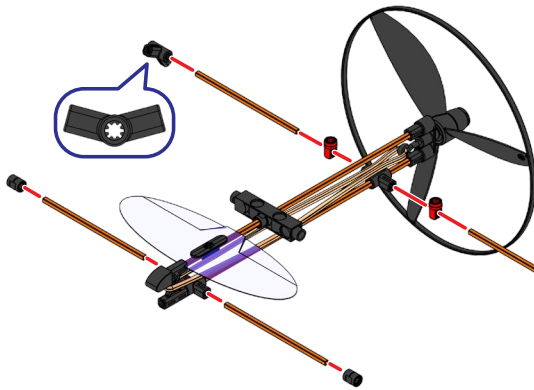
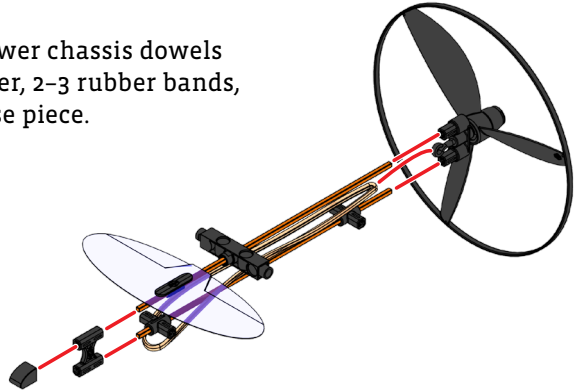

- 6** Assemble the four wheel holder rods with 90 mm dowels 1 as shown.

- 7** Attach the front wheels with 3-hole rods and short shaft plugs. Attach the rear wheels with 90 mm dowels 1 and dowel holder shafts.



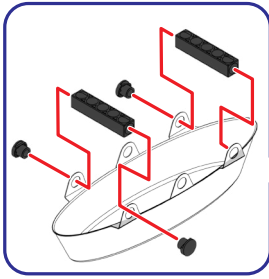

8 Attach the right-side body piece (hull) to the chassis as shown.

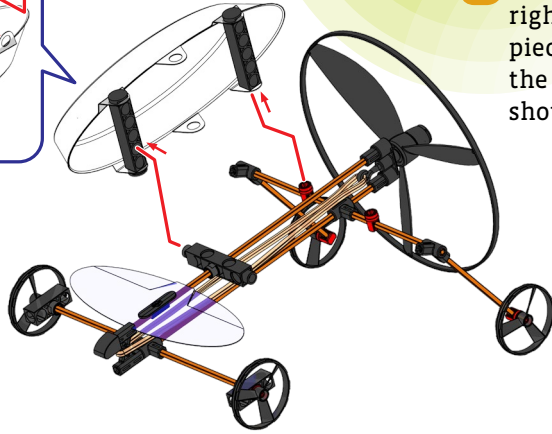

9 Attach the left-side body piece to the chassis as shown.

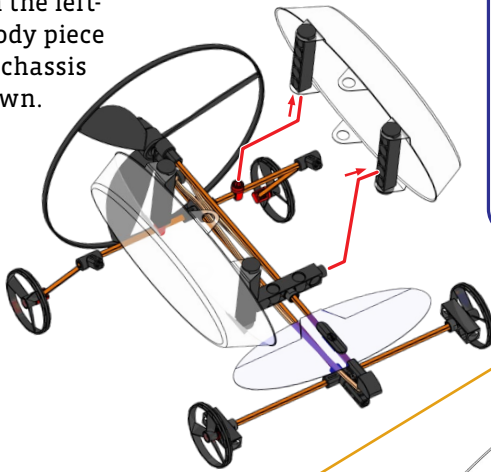
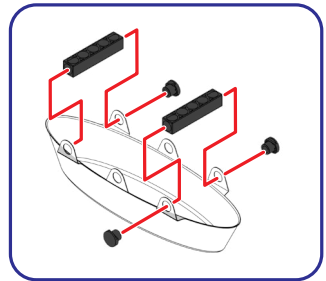

Wind



10 To drive the car, wind up the rubber bands by spinning the propeller in the direction indicated 60–80 times. Put the car on a smooth, flat surface and let go of the propeller. The propeller pushes the car forward.

Wind 60–80 rotations.



ALL ABOUT ELASTIC ENERGY

What makes your rubber band powered vehicles go? It's a special property of rubber that allows it to store and release energy!

Rubber is a natural material from trees that has a property called **elasticity**. Elasticity is a physical property of a material that describes the material's ability to resume its original shape after being stretched or compressed. The force applied to a material to make it stretch or compress is called **stress**. The amount a material changes shape when under stress is called **deformation**, or **strain**. The strength of a material relates to its ability to resist deformation under stress.

A rubber band has a shape when it is at rest. When stress is applied to it, such as pulling or twisting, it stretches and changes shape. When the stress is removed, the elasticity of the rubber band allows it to return to its original shape.

A law of physics called **Hooke's law** states that when a stress is applied to an elastic object, the change in length of the object is directly proportional to the amount of load, up to a point. Beyond that point, known as the elastic limit, the object will break and not return to its original shape after the stress has been removed.

Because **energy** goes into the rubber band when stress is applied,

and energy cannot be created or destroyed, then it stands to reason that energy comes out of the rubber band when it snaps back to its original shape — that is, as long as you don't exceed the elastic limit and break the rubber band. This energy release can then be used to do other work, such as spinning a propeller!

In your rubber band models, you are storing energy in the elastic rubber band when you use the force from your fingers to wind it up. The stored energy is called **potential energy**. When you let the propeller go and it unwinds, the potential energy is converted to **kinetic energy**, or energy of movement.

The tighter the elastic band is wound, the more potential energy it contains. When released, more work is generated and your vehicles can start faster and move longer.

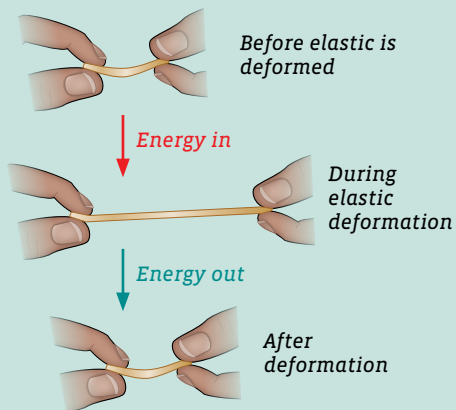

PART 3

PROPELLERS ON THE WATER

All aboard!



Model 4: Airboat

- 1 Assemble the propeller.

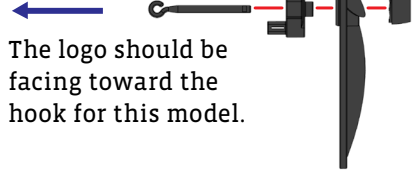
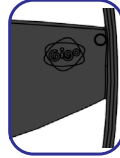
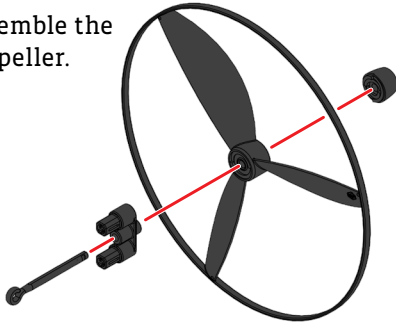

The logo should be facing toward the hook for this model.

- 2 Put the cap on the propeller.

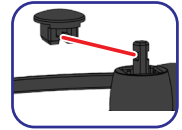
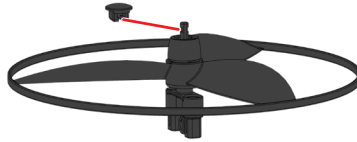

- 3 Assemble the boat body as shown using two 220 mm dowels ② and 2-3 rubber bands.

Use 2-3
rubber bands.

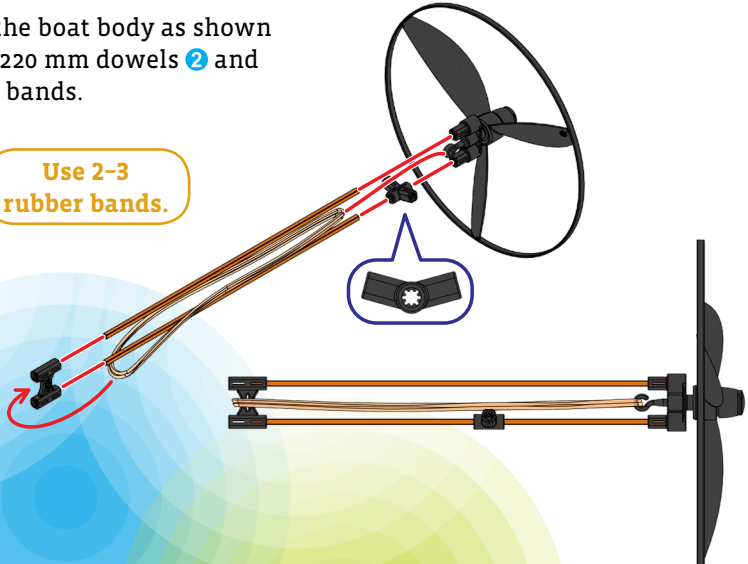

4 Assemble the two hulls as shown.

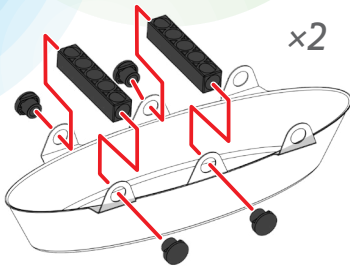

5 Attach a 220 mm dowel 2.

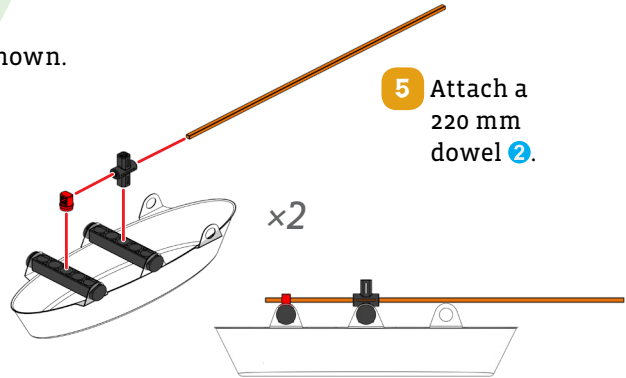

6 Attach the left and right stabilizer films. Attach a 90 mm dowel 1 and a straight connector to each hull.

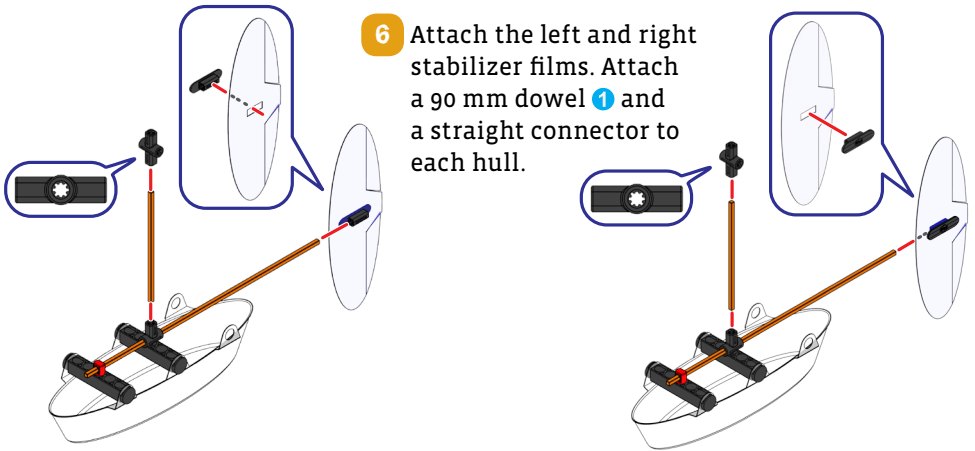

7 Attach the hulls to the boat body with two more 90 mm dowels 1.



8 Wind up the propeller 60-80 times in the direction indicated. Set the boat in a bathtub or kiddie pool with shallow water and let it go! The air pushes the boat forward.



Model 5: Hydrofoil

- 1 Assemble the propeller.

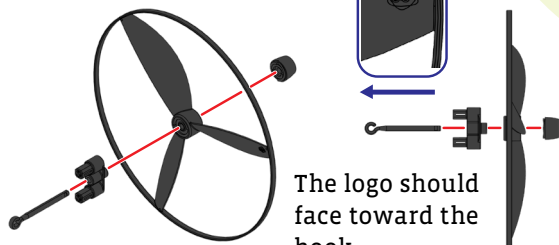

- 2 Put the cap on the propeller.

- 3 Assemble the hydrofoil propeller shaft as shown using two 220 mm dowels 2 and 2-3 rubber bands.

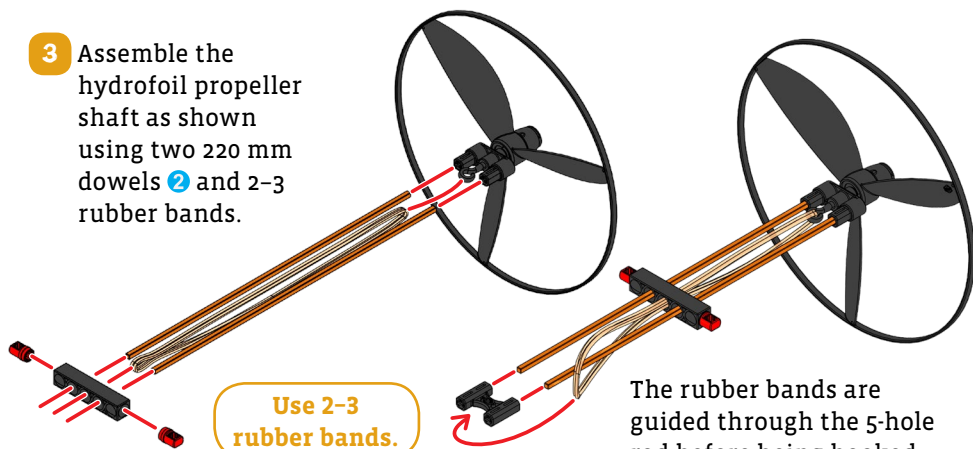

The rubber bands are guided through the 5-hole rod before being hooked over the bridge connector.



- 4 Attach the stabilizer films as shown with two 90 mm dowels 1.

5 Assemble the hull with two more 90 mm dowels **1**.

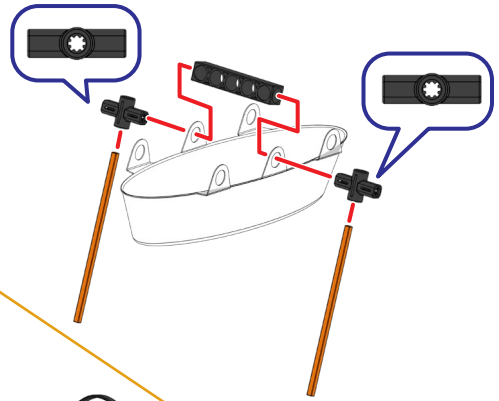

6 Attach the hull to the propeller shaft.

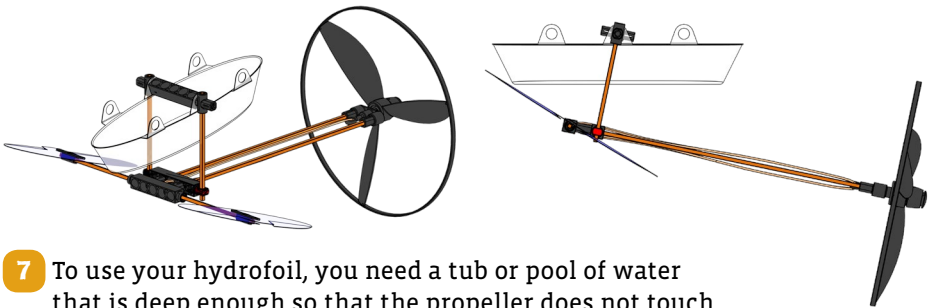
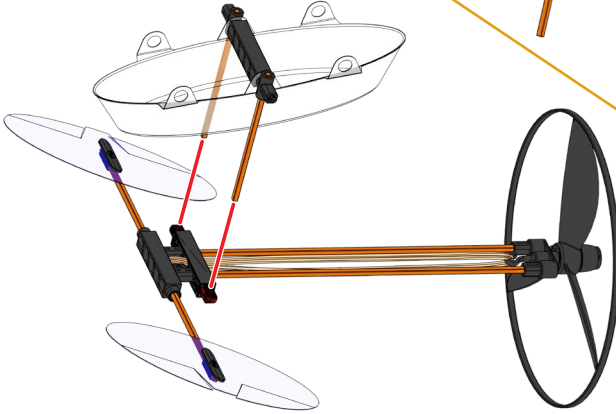

7 To use your hydrofoil, you need a tub or pool of water that is deep enough so that the propeller does not touch the bottom when the hull floats on the water's surface. Wind up the propeller 60-80 times in the direction indicated, hold it as you gently place the hull in the water. Let go and the forward motion caused by the propeller will cause the hydrofoil to lift up as it travels through the water.

Wind 60-80 rotations.

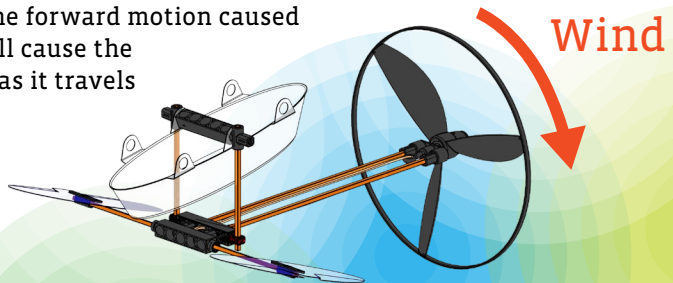

**GEEK
OUT!**

AIRBOATS AND HYDROFOILS

These boats
blow me away!



Airboats (also called fanboats) use big propellers just like the ones on airplanes to push them through the water. Because the propeller doesn't actually go into the water, airboats can glide over bodies of water full of plants and debris in which normal motorboats would get stuck.

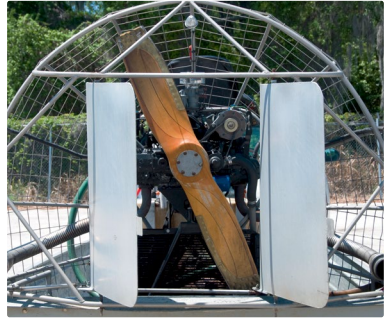

Fan boat

Propeller on fan boat

To steer an airboat, air from the fan is guided past large rudders. The captain just has to adjust the direction of these rudders in order to steer. Airboats are popular for transporting people in the swampy areas of Florida and other southern U.S. states.

Hydrofoils are boats that have wing-like devices attached to their hulls. The wings, also called hydrofoils, generate a lifting force in the water when they are moving fast enough. They work in water the same way wings work in the air. The hydrofoil lets boats "fly" mostly on top of the water's surface, reducing friction. When the boat slows down though, it will sink into the water, so a buoyant hull is also needed.



Hydrofoil

MEET THE NEXT-GEN GEEKERS!

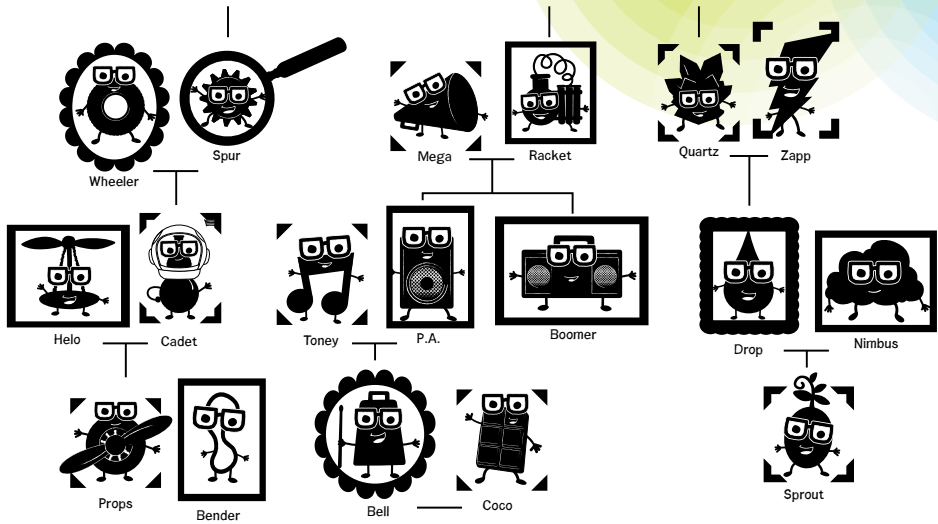

2nd Edition © 2015, 2016 Thames & Kosmos, LLC, Providence, RI, USA
 Thames & Kosmos® is a registered trademark of Thames & Kosmos, LLC.

This work, including all its parts, is copyright protected. Any use outside the specific limits of the copyright law without the consent of the publisher is prohibited and punishable by law. This applies specifically to reproductions, translations, microfilming, and storage and processing in electronic systems and networks. We do not guarantee that all material in this work is free from copyright or other protection.

Concept: Thames & Kosmos and Genius Toy Taiwan Co. Ltd.

Technical product development and project management: Thames & Kosmos, Genius Toy Taiwan Co. Ltd., Sebastian Martin, Dr. Petra Müller

Text: Ted McGuire

Original manual layout and artwork: Ted McGuire, Dan Freitas

Manual illustrations and photos: lunamarina, iStock, p. 16 (airboat); iStock, p. 16 (hydrofoil); John Panella, © shutterstock.com, p. 16 (propeller)

All other illustrations by Genius Toy Taiwan Co. Ltd., and Dan Freitas, Ashley Greenleaf, and Ted McGuire of Thames & Kosmos
 Packaging artwork and photos: Genius Toy Taiwan Co. Ltd., Dan Freitas

The publisher has made every effort to locate the holders of image rights for all of the photos used. If in any individual cases any holders of image rights have not been acknowledged, they are asked to provide evidence to the publisher of their image rights so that they may be paid an image fee in line with the industry standard.

Distributed in North America by Thames & Kosmos, LLC, Providence, RI 02903
 Phone: 800-587-2872; Web: www.thamesandkosmos.com

Distributed in United Kingdom by Thames & Kosmos UK, LP, Goudhurst, Kent TN17 2QZ
 Phone: 01580 212000; Web: www.thamesandkosmos.co.uk

We reserve the right to make technical changes.
 Printed in Taiwan / Imprimé en Taiwan



Kosmos Quality and Safety

More than one hundred years of expertise in publishing science experiment kits stand behind every product that bears the Kosmos name. Kosmos experiment kits are designed by an experienced team of specialists and tested with the utmost care during development and production. With regard to product safety, these experiment kits follow European and US safety standards, as well as our own refined proprietary safety guidelines. By working closely with our manufacturing partners and safety testing labs, we are able to control all stages of production. While the majority of our products are made in Germany, all of our products, regardless of origin, follow the same rigid quality standards.